

---

# Experimental Particle Physics

---

## Particle Interactions and Detectors

# How do we detect Particles?

## ■ Particle Types

- ❑ Charged ( $e^-/K^-/\pi^-$ )
- ❑ Photons ( $\gamma$ )
- ❑ Electromagnetic ( $e^-$ )
- ❑ Hadronic ( $K^-/\pi^-/\mu^-$ )
- ❑ Muonic ( $\mu^-$ )
- ❑ Gravitons !

## ■ Interaction with matter

- ❑ Ionisation Loss
- ❑ Radiation Loss
- ❑ Photon Absorption
- ❑ Electromagnetic Showers
- ❑ Hadronic Showers
- ❑ Cherenkov Radiation
- ❑ Transition Radiation

**In general, we measure the energy lost as the particle passes through a medium.**

# Transverse slice through CMS detector

Click on a particle type to visualise that particle in CMS

Press "escape" to exit

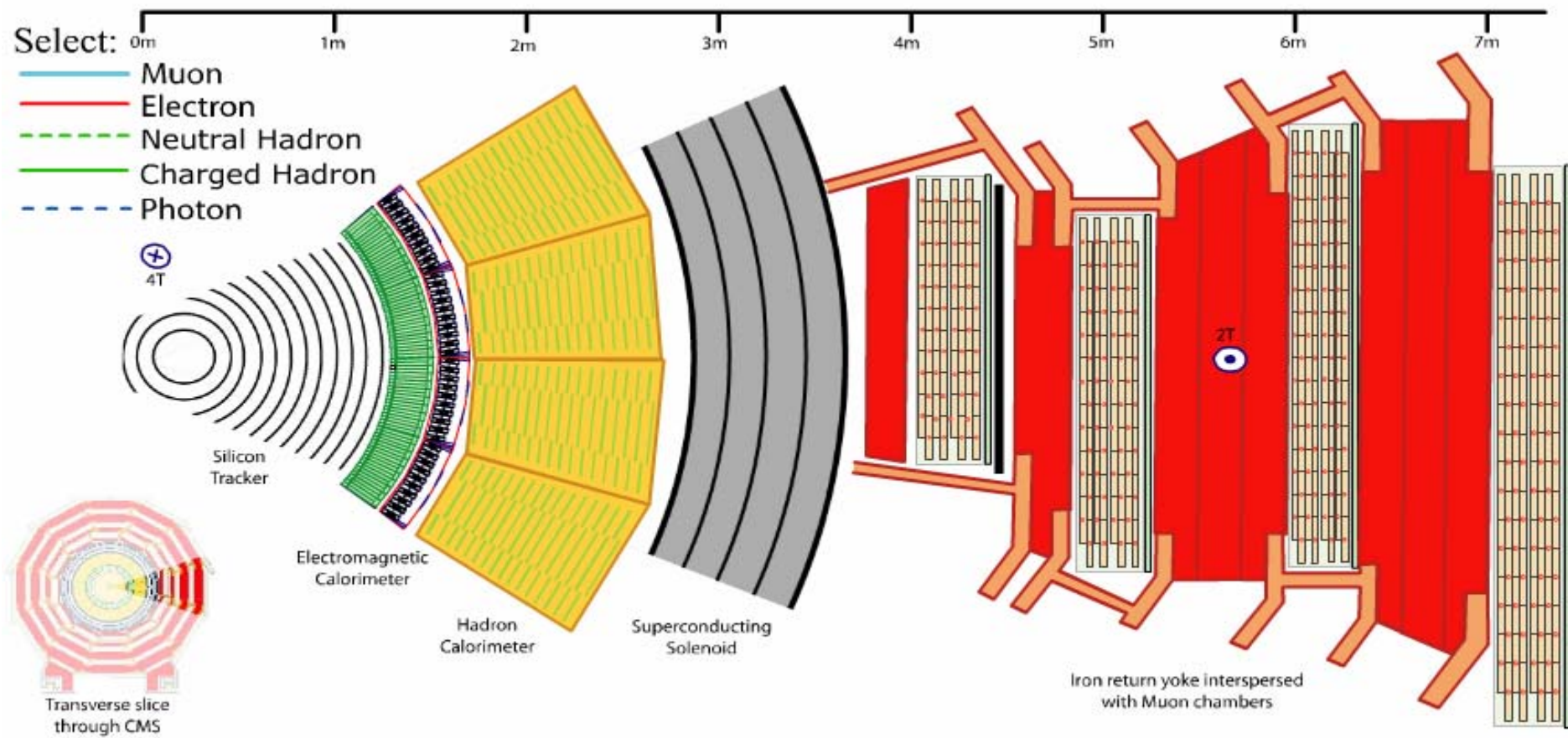

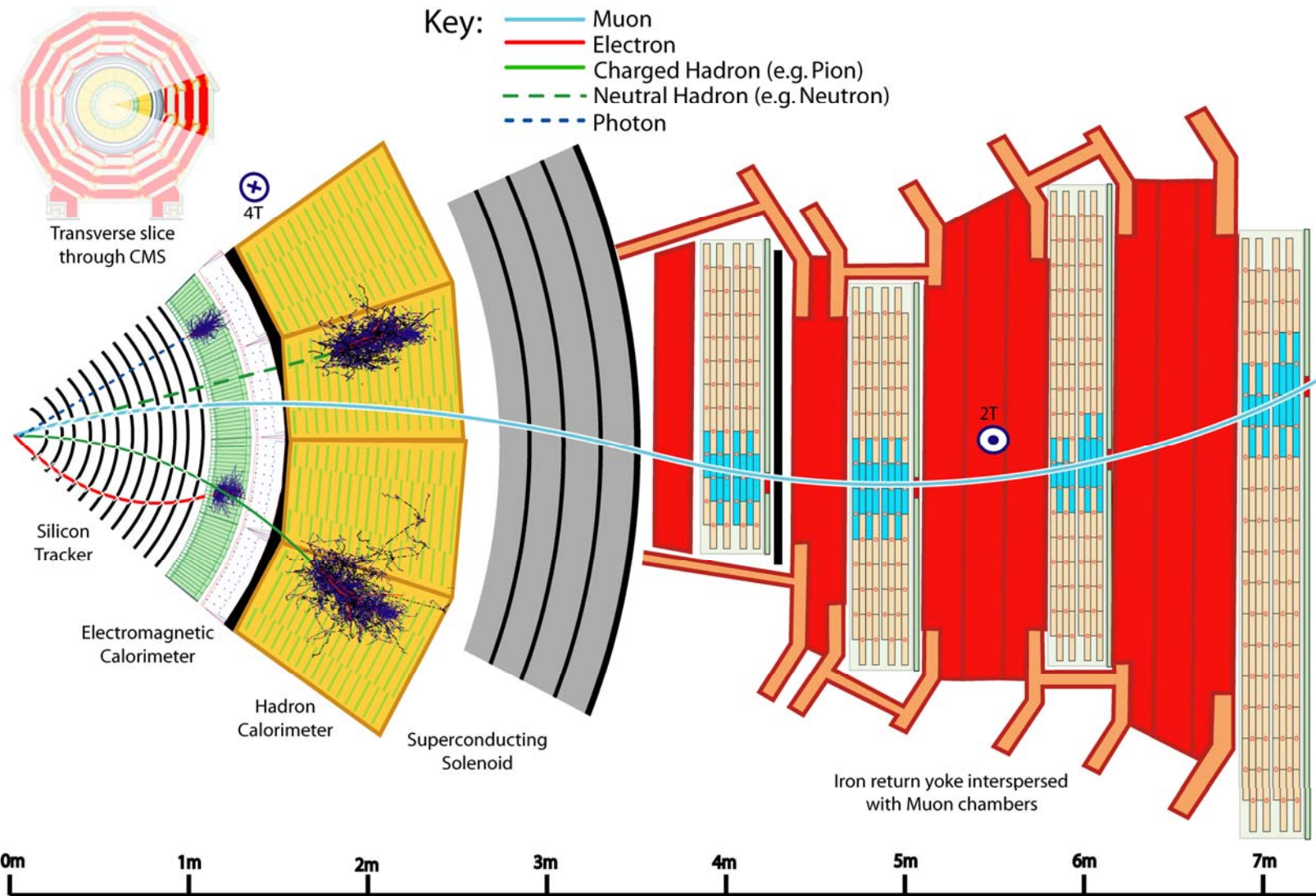

# Which particles interact with which subdetector?

(caveat: some particles leave a small signal in a subdetector e.g. muon in EM calorimeter)

<b>Detector</b>	<b>Electron</b>	<b>Charged Hadron (<math>K^+/\pi^+</math>)</b>	<b>Muon</b>	<b>Neutral Hadron (<math>\pi^0</math>)</b>	<b>Photon</b>
<b>Tracking</b>	Yes	Yes	Yes		
<b>Cherenkov</b>		Yes			
<b>Transition Radiation</b>	Yes	Yes			
<b>EM Calorimeter</b>	Yes				Yes
<b>Hadronic Calorimeter</b>		Yes		Yes	
<b>Muon Detector</b>			Yes		

---

# Charged Particle Detectors

## ■ Physics

- Ionisation
- Mean Energy Loss
- Fluctuations
- Cherenkov Light
- Transition Radiation

## ■ Detectors

1. Emulsion
2. Bubble Chambers
3. Scintillation Detectors
4. Wire Chambers
5. Multi Wire Proportional Chambers (MWPC)
6. Geiger Muller
7. Solid State Devices
8. Time Projection (TPC)
9. Resistive Plate Counters (RPC)
10. Limited Streamer Tubes (LST)
11. Cherenkov
12. Transition Radiation (TRD)

# Ionisation and Atomic Excitation

- Heavy Charged particles interact with electrons in material as they pass
- Can be calculated: *The Bethe-Bloch Equation*
- Ok for energies between 6 MeV and 6 GeV
- Function only of  $\beta$  (approximately)

Constant

$$-\frac{dE}{dx} = Kq^2 \frac{Z}{A\beta^2} \left[ \frac{1}{2} \ln \frac{2m_e c^2 \beta^2 \gamma^2 T_{\max}}{I^2} - \beta^2 - \frac{\delta(\beta\gamma)}{2} \right]$$

$\approx 1/2$ 
Ionisation Constant for material
Density correction

**Maximum energy loss in single collision**  
 $T_{\max} \approx 2m_e c^2 \beta^2 \gamma^2$

**Stopping Power**



# Stopping Power

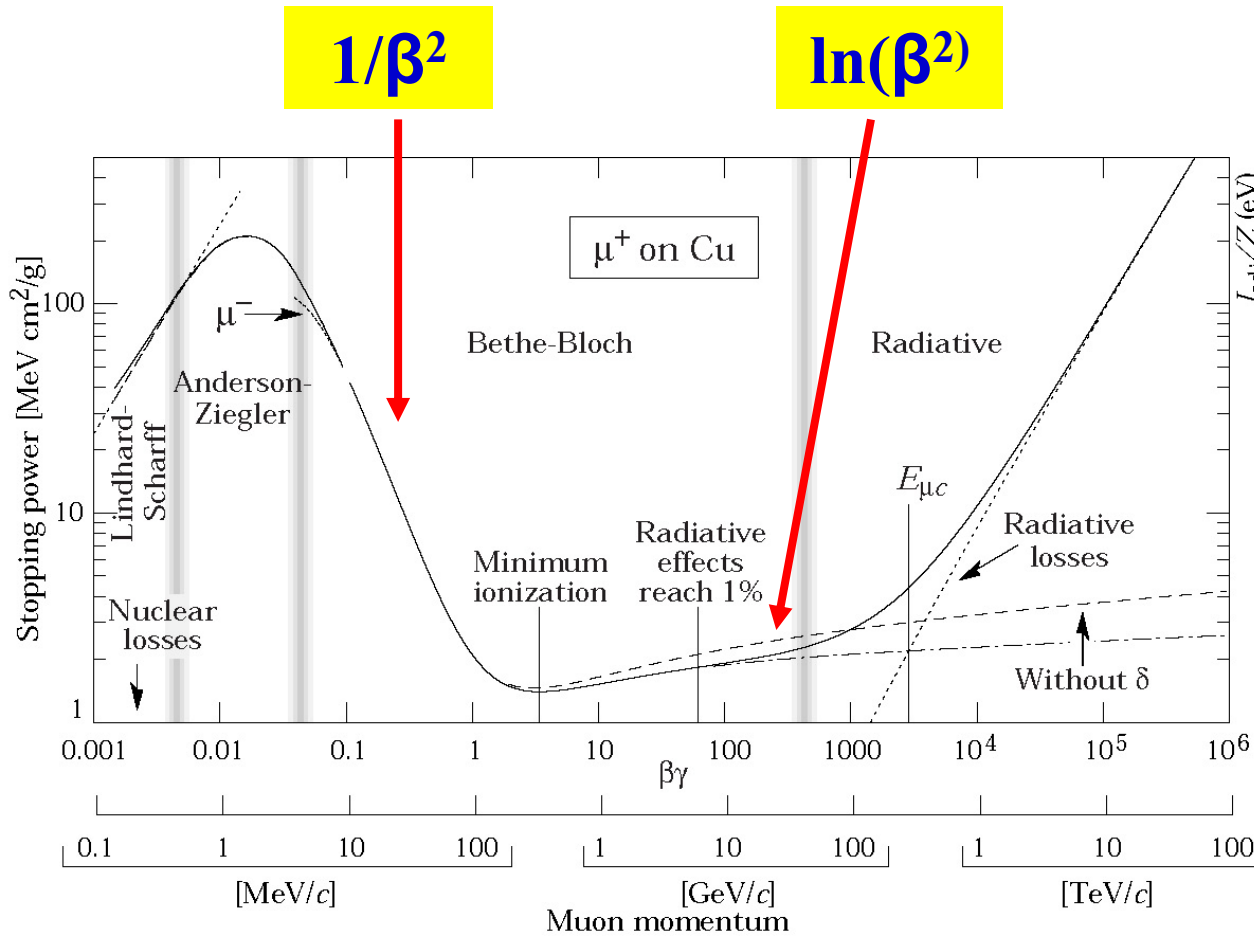

## Ionisation Constant

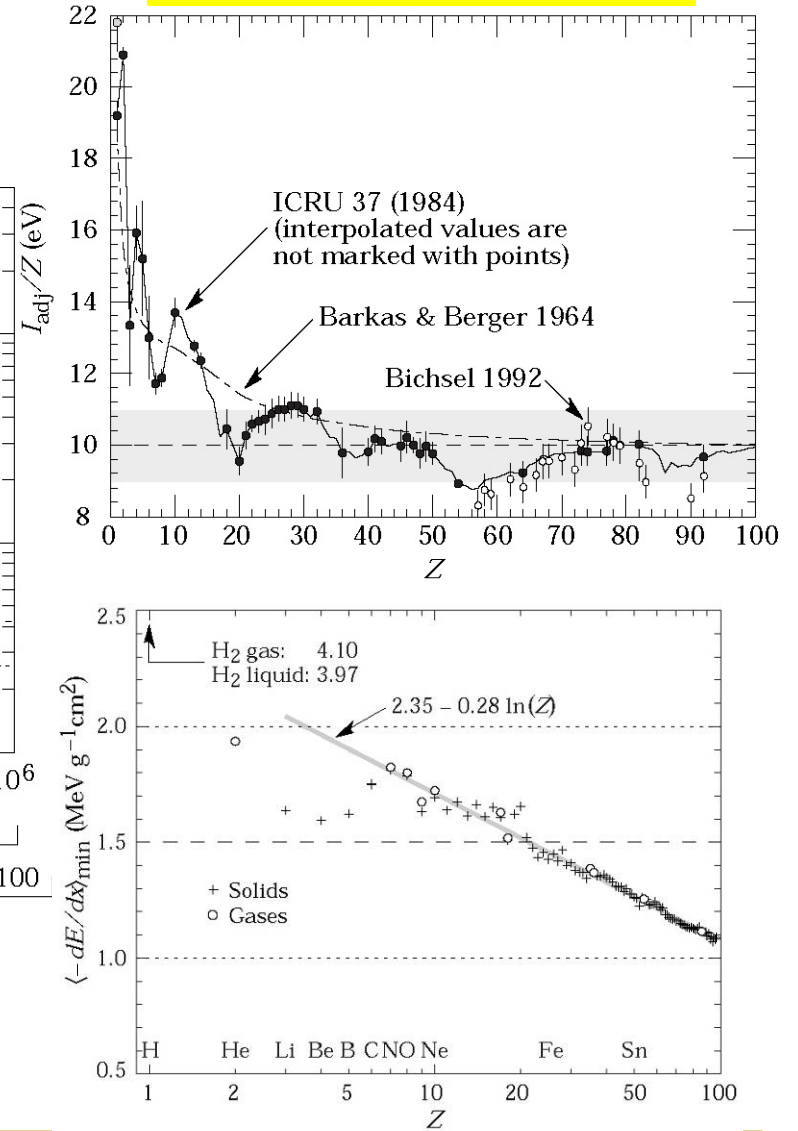



# Mean Energy Loss in different materials

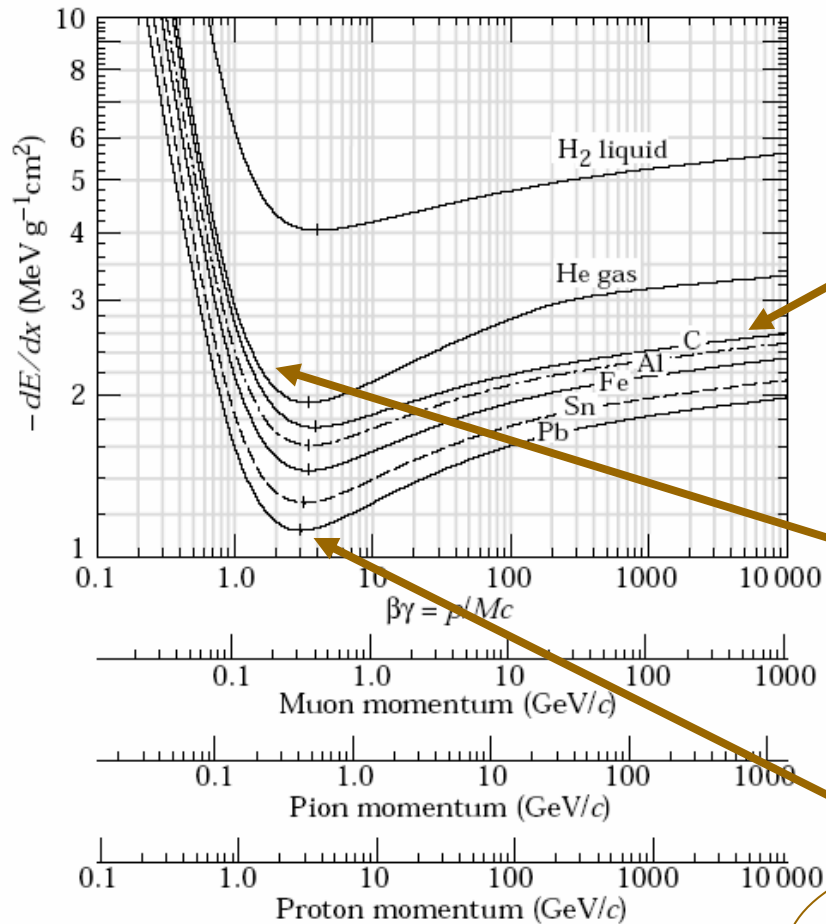

**High energy**  
 $\sim \ln \gamma$

$$-\frac{dE}{dx} \approx Kq^2 \frac{Z}{A\beta^2} \left[ \ln \frac{2m_e c^2 \beta^2 \gamma^2}{I^2} - \beta^2 \right]$$

**Low energy**  
 $\sim 1/\beta^2$

**Minimum at**  
 $\gamma \approx 3$

**Distance units:**

**➤ g cm<sup>-2</sup>**

# Energy Fluctuations

- Bethe-Block only gives mean, *not* most probable
- Large high energy tail –  $\delta$  rays
- Landau distribution:

**$\delta$ -rays : electrons produced by the Bethe-Block equation that have sufficient energy to ionize further atoms through subsequent interactions on their own.**

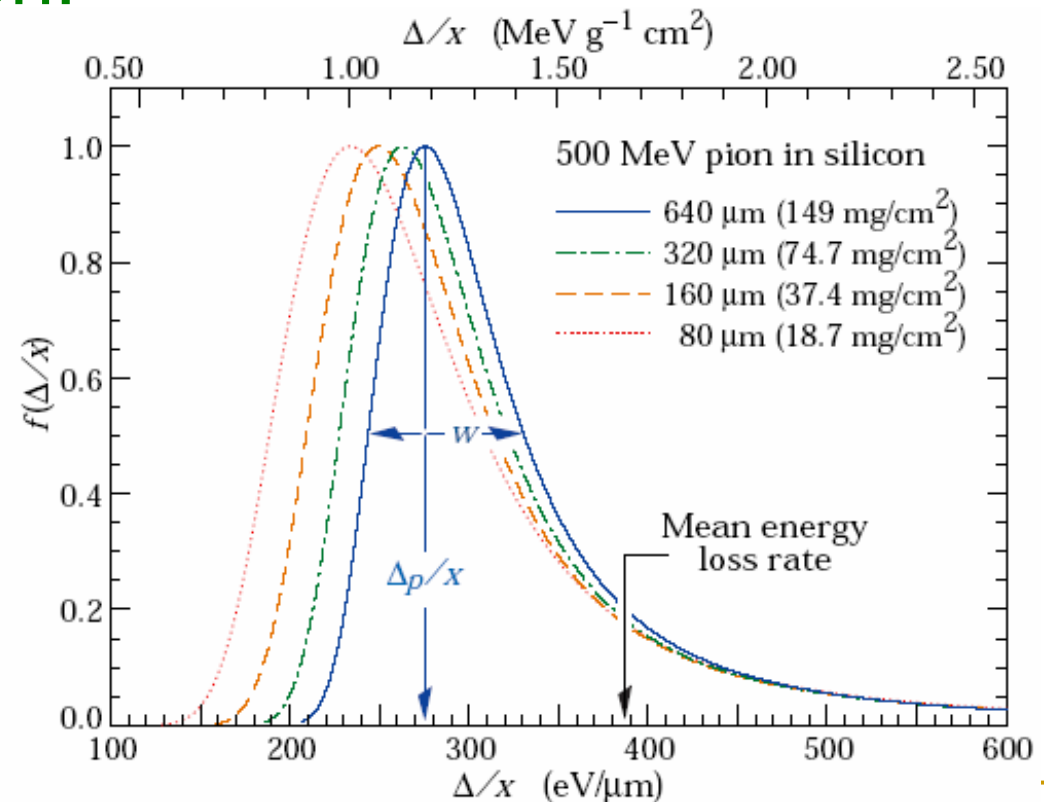

# Particle Identification by Energy Loss

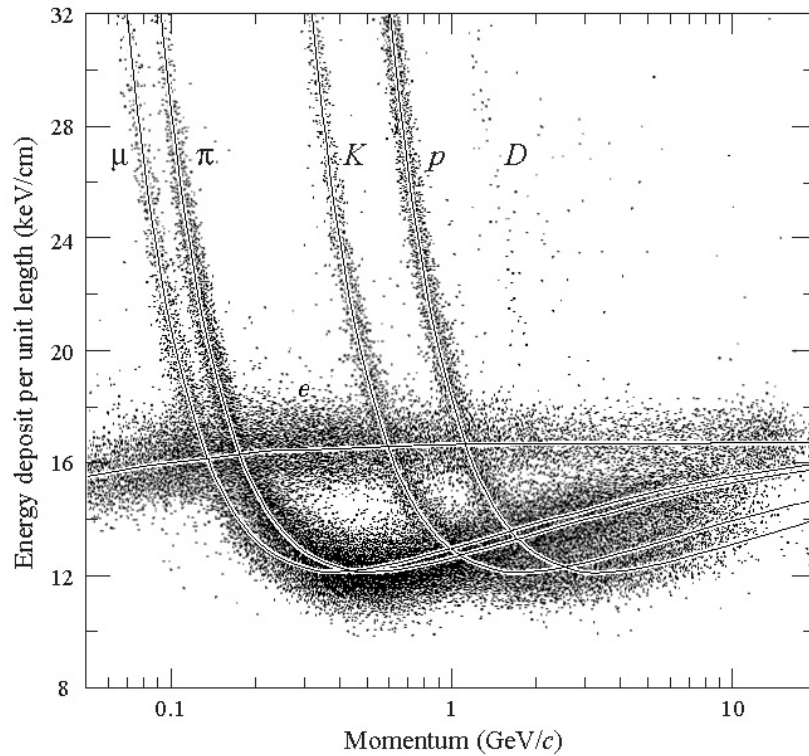

**Results from a Time  
Projection Chamber  
(PEP4/9)**

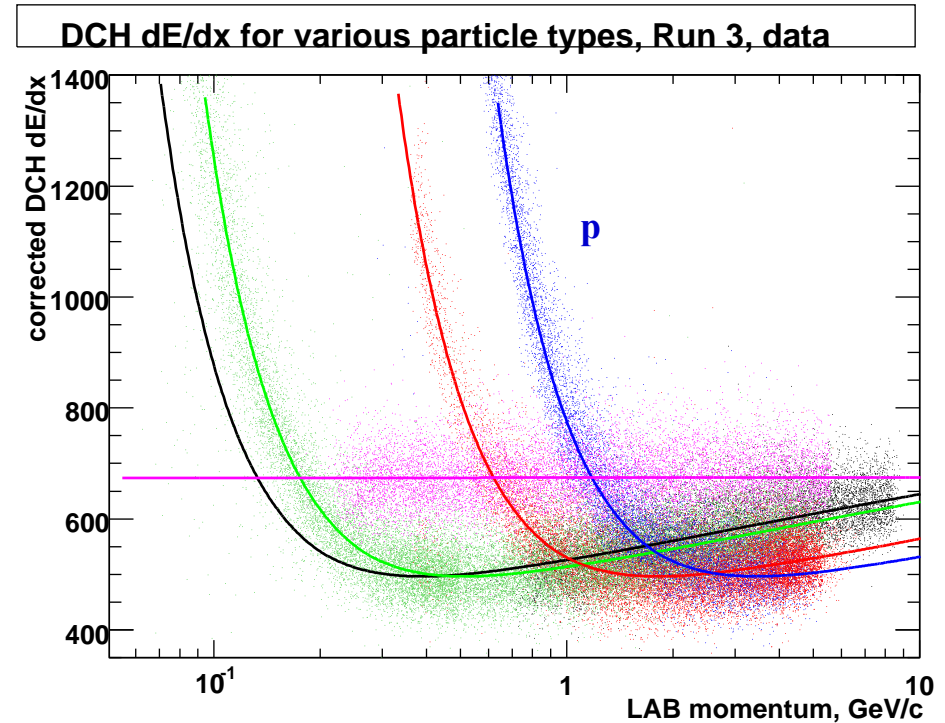

**Results from a Drift  
Chamber  
(BaBar)**

# Ionisation Detectors

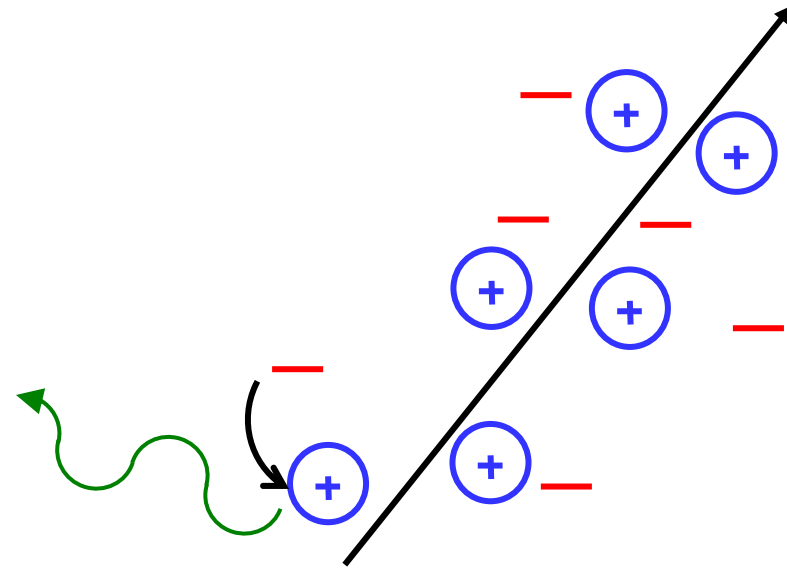

Ionisation used to detect particles in different ways:

1. Observe **physical** or **chemical** change due to ions
2. Detect energy from recombination - **scintillation**
3. Collect and measure free charges - **electronic**

# Emulsions

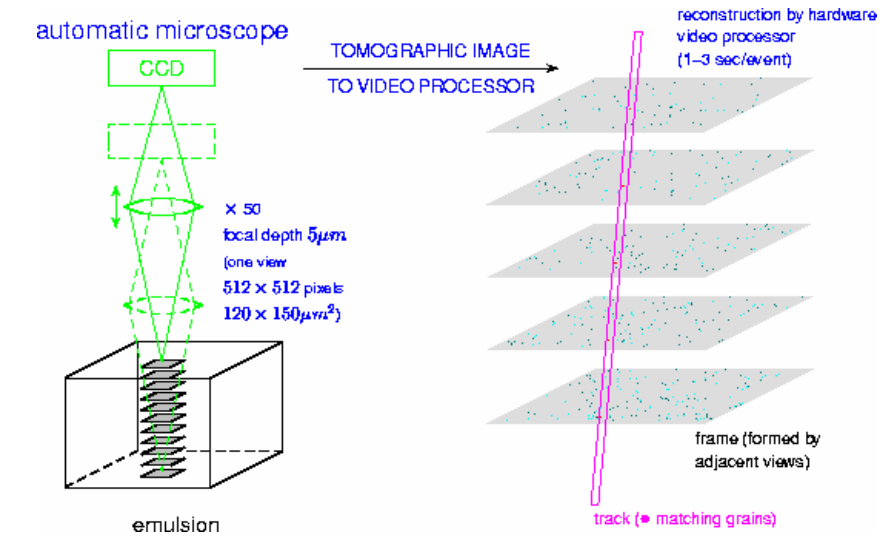

- Expose film to particles and develop
- Natural radioactivity was discovered this way
- Still occasionally used for very high precision, low rate experiments
- Similar technique in etched plastics

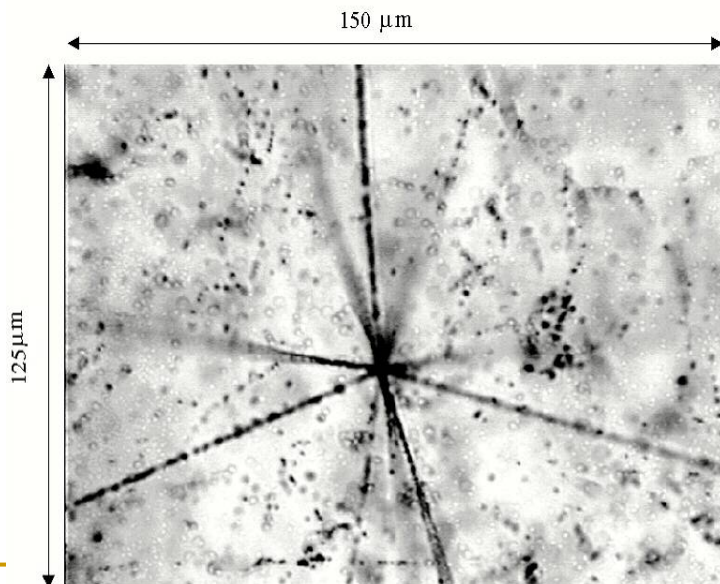

**CHORUS  
(neutrinos)**

# Bubble Chambers (1960s-1970s)

- Ionisation trail nucleates bubbles in superheated liquid
- Liquid  $H_2$  (or similar) close to boiling point
- Suddenly reduce pressure.
- Fire beam into chamber
- Take photo
- Cloud chamber similar: ions nucleate condensation in saturated vapour



**BEBC**

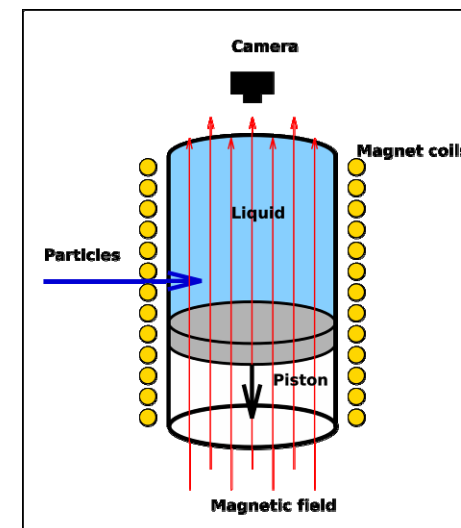
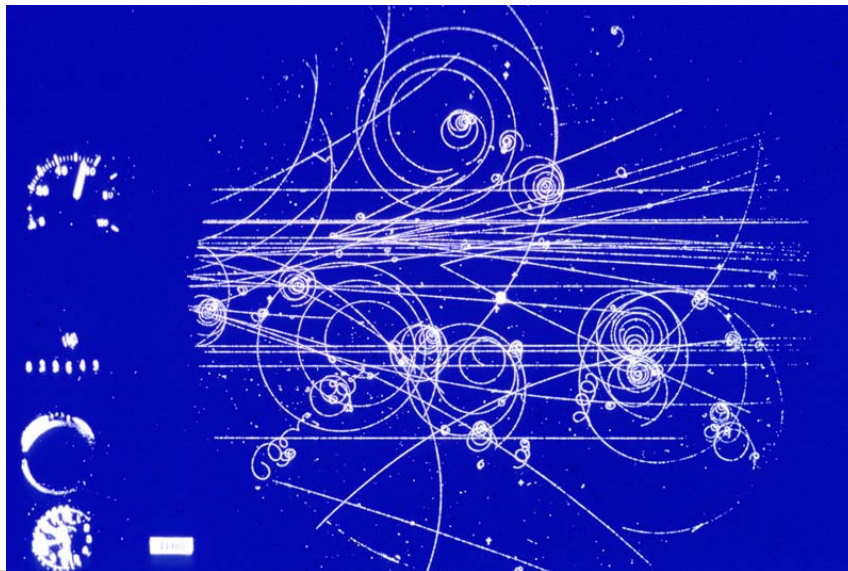



# Scintillation Detectors

Detect photons from electronic recombination of ions

- Organic (plastic)
- Inorganic (crystal or glass)
  - **doping normally required**

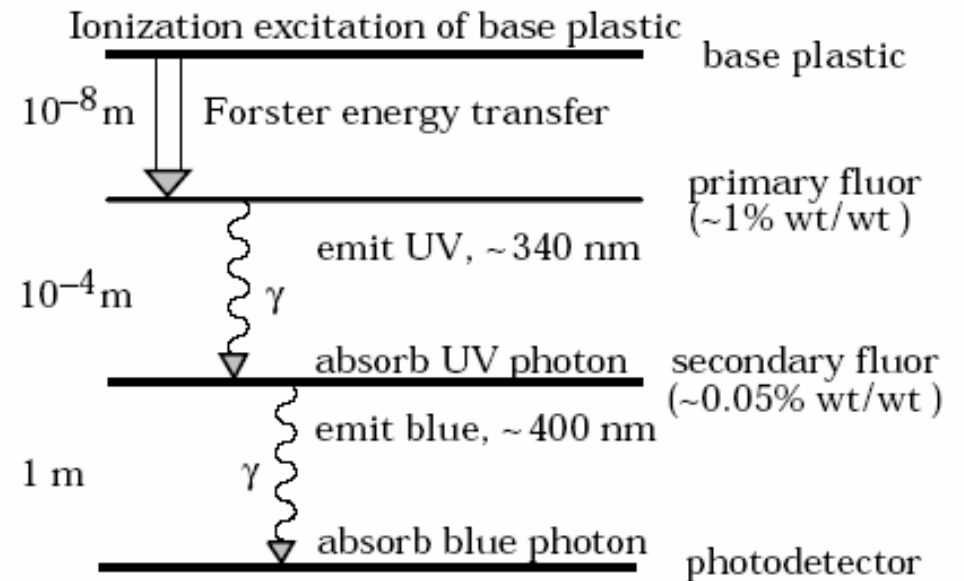
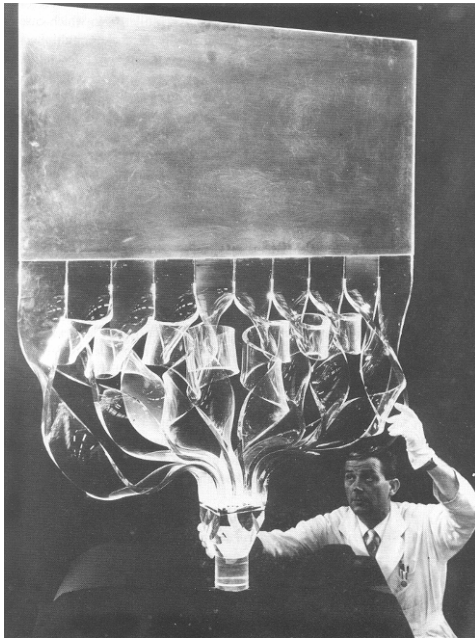

- Not very efficient  $\sim 1$  photon/100eV
- Light carried to sensitive photodetectors
- **Fast, cheap and flexible**



# Wire Chambers

- Free electrons will be attracted to anode
- Electric field near **thin wire** increases
- Secondary ionisation may start to occur
  - *avalanche!*
- *A typical gas detector will have ~20 primary ions per cm created by a track.*

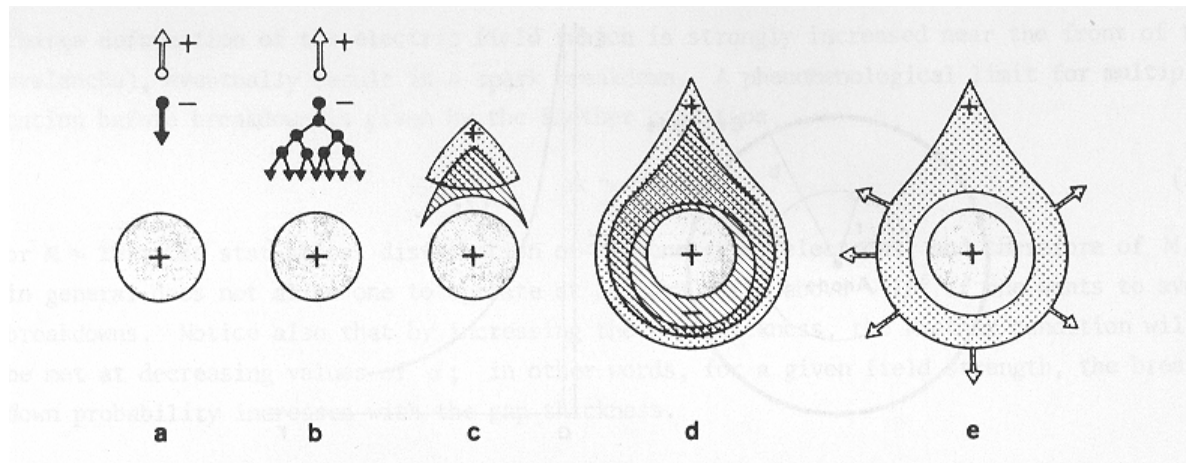
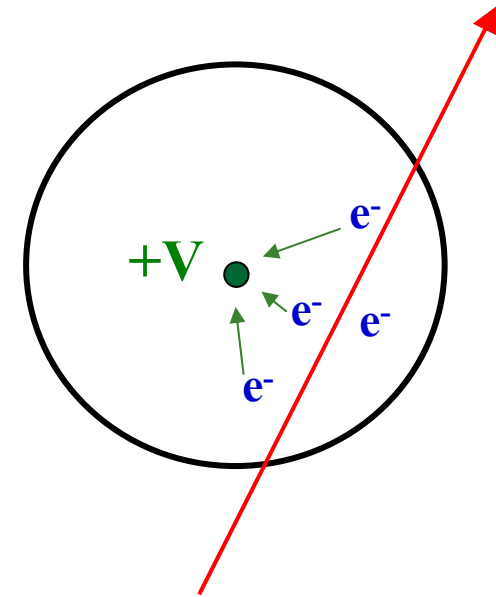

# Gas Amplification

Proportional Chambers

Maximum gain  $\sim 10^7$

Avalanche fills volume

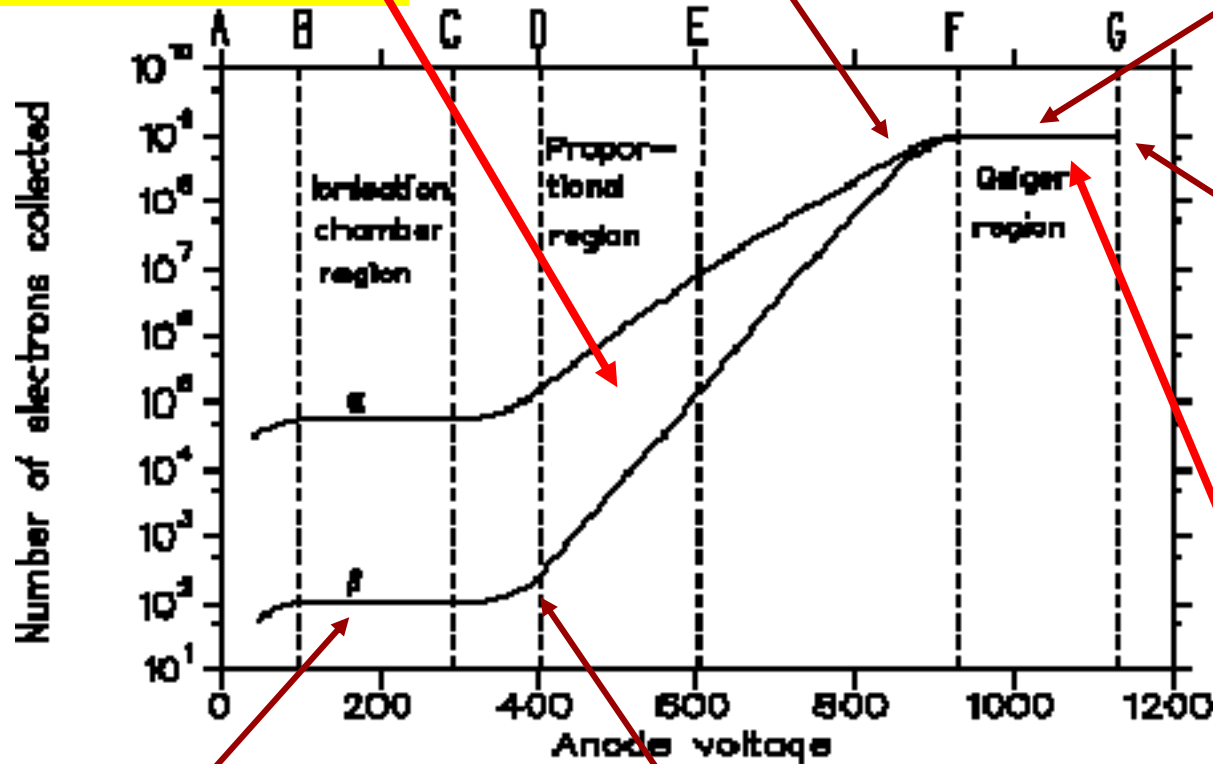

Arcing

- Geiger Muller Tube
- Resistive Plate Chambers

Full charge collection

Start of avalanche region

# Geiger Region

- Geiger Counter
- Spark Chamber
  - short bias pulse->localise breakdown
- Streamer Chamber
  - Large volume, transparent electrodes

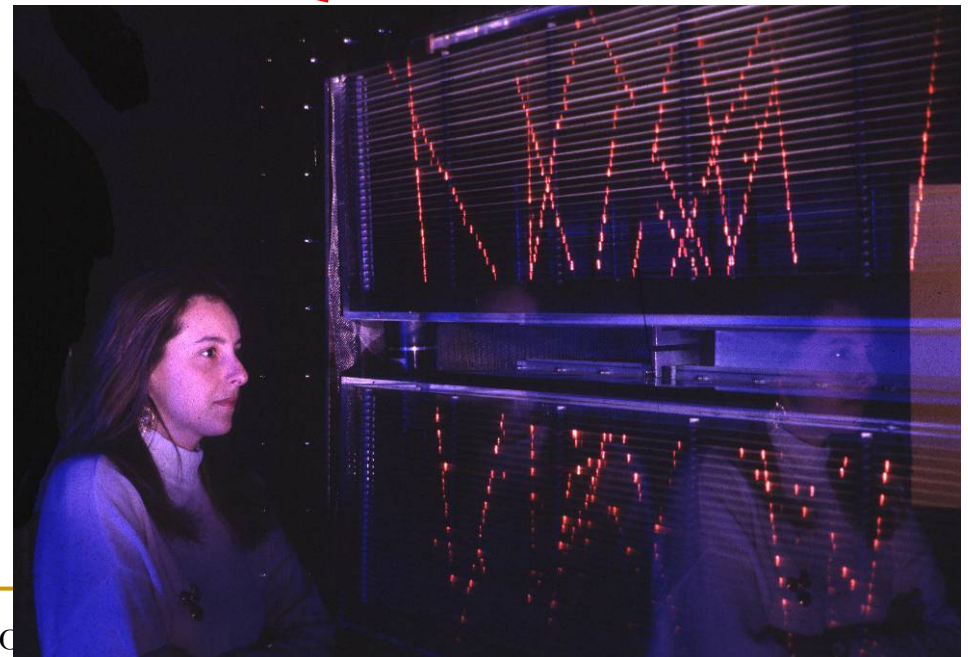
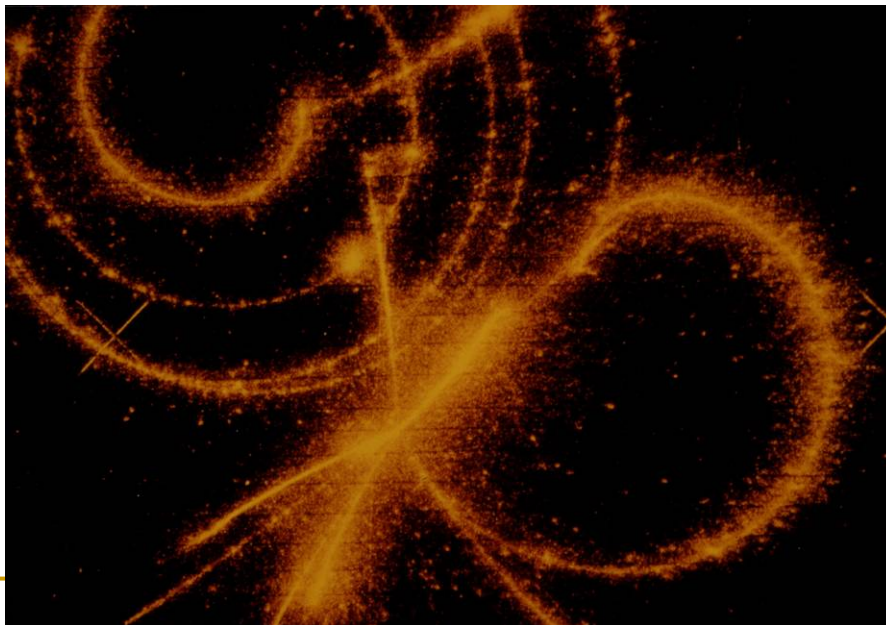

# MWPC

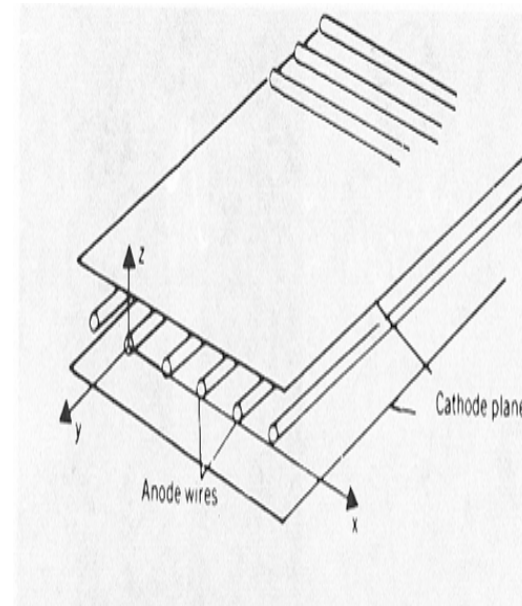
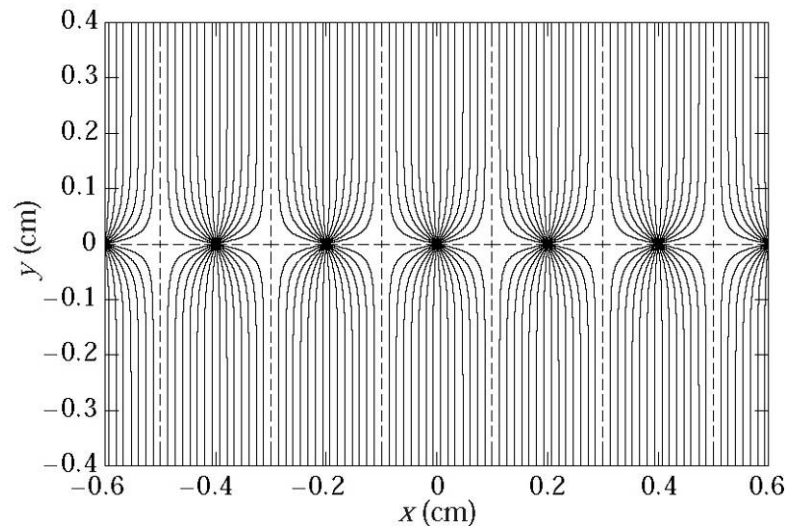

- Need better idea for large volume coverage at high rates
  - ❑ Multi-Wire Proportional Chamber
  - ❑ Fast
    - Ion Drift Velocity  $\sim 50$  km/s ( $50 \mu\text{m/ns}$ )
  - ❑ Resolution  $\sim \text{pitch}/\sqrt{12}$
  - ❑  $x$  from anode
  - ❑  $y$  from ions at segmented cathode plane

# Drift Chambers

- Electron drift speed depends on electric field and gas
- Time delay of hit gives distance from sense anode
- Extra wires can be used to separate drift and avalanche regions
- Typical values:
  - drift distance  $\sim$ cm
  - drift time  $\sim$  $\mu$ s
  - precision  $\sim$ 100  $\mu$ m

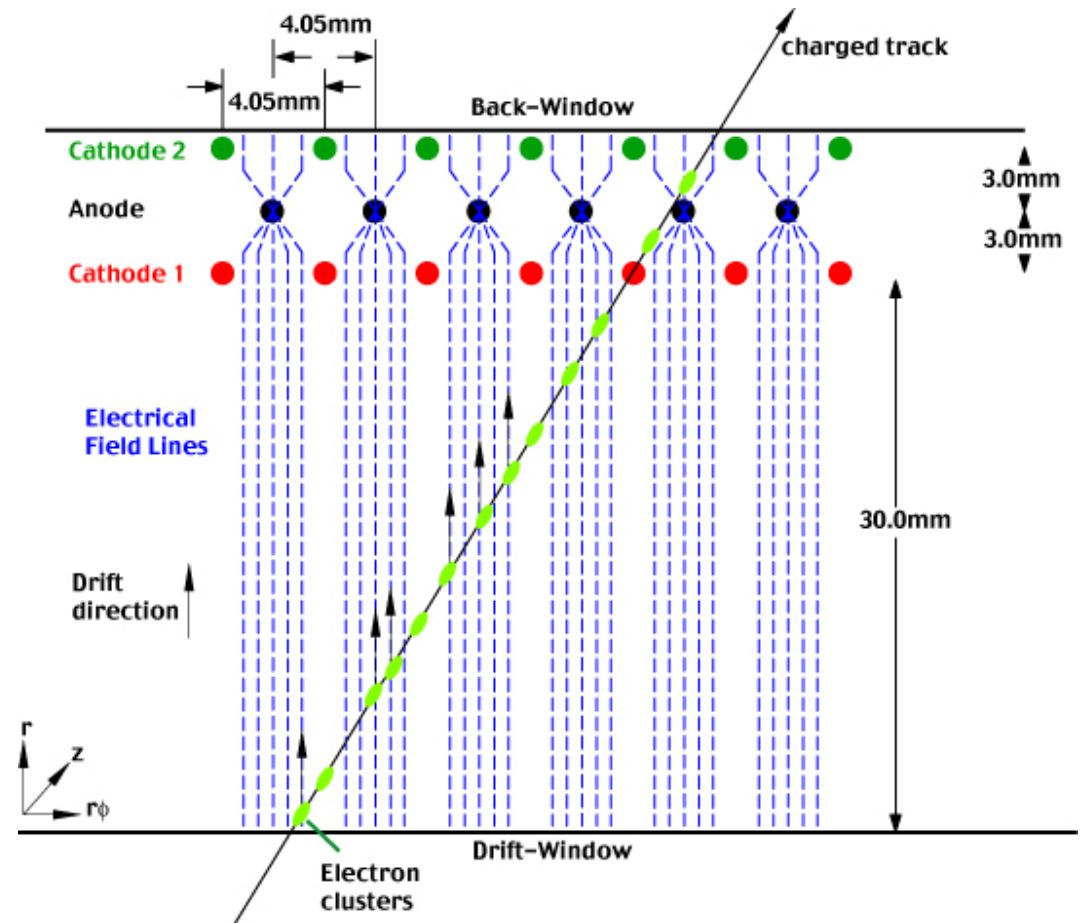



# Stereo Readout

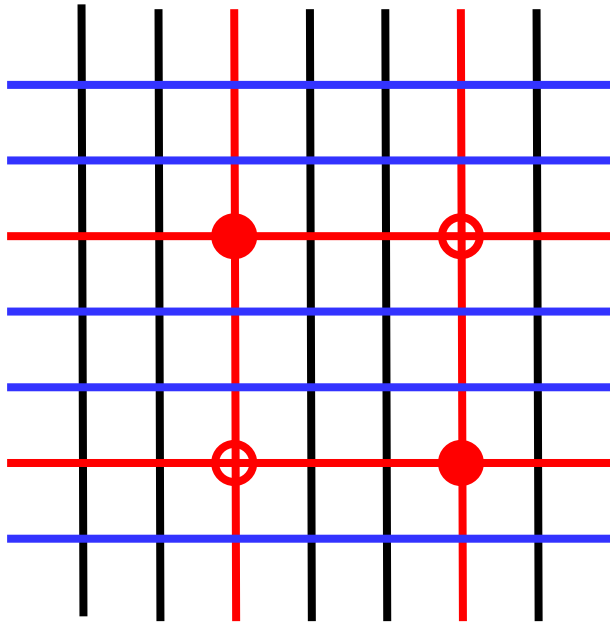

- Good z resolution
- Need readout along length
- Ghost hits

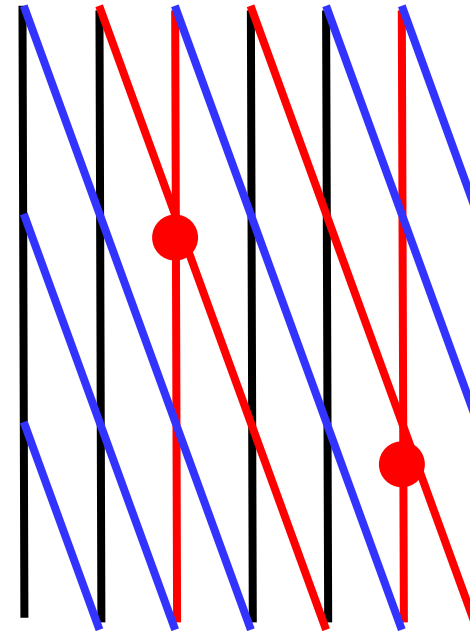

- Good pattern recognition
- Readout from ends
- Poor z resolution

# BaBar Drift Chamber

## Open Cell Drift Chamber

- 2.8 m long
- Gas volume  $\sim 5.6 \text{ m}^3$
- 7100 anode wires
- Axial and stereo
- $\sim 50,000$  wires in total

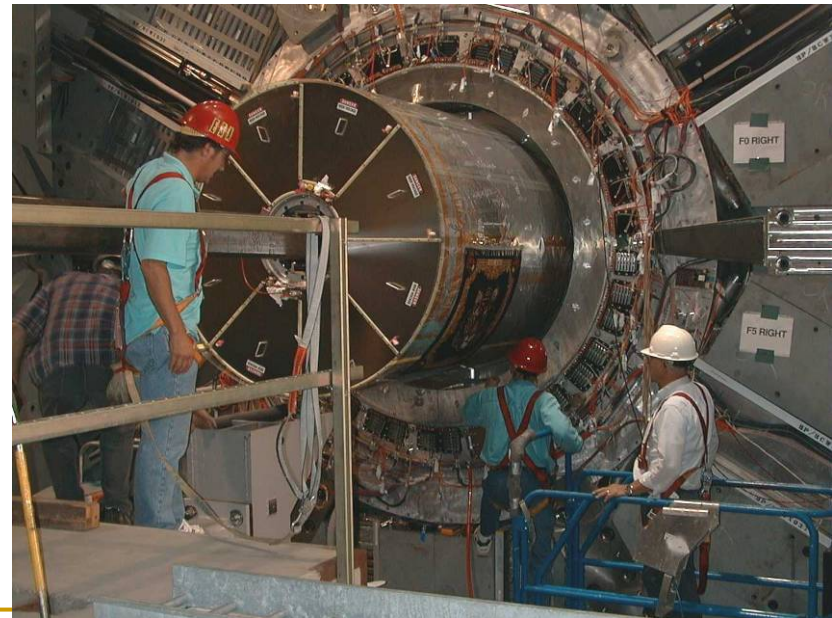
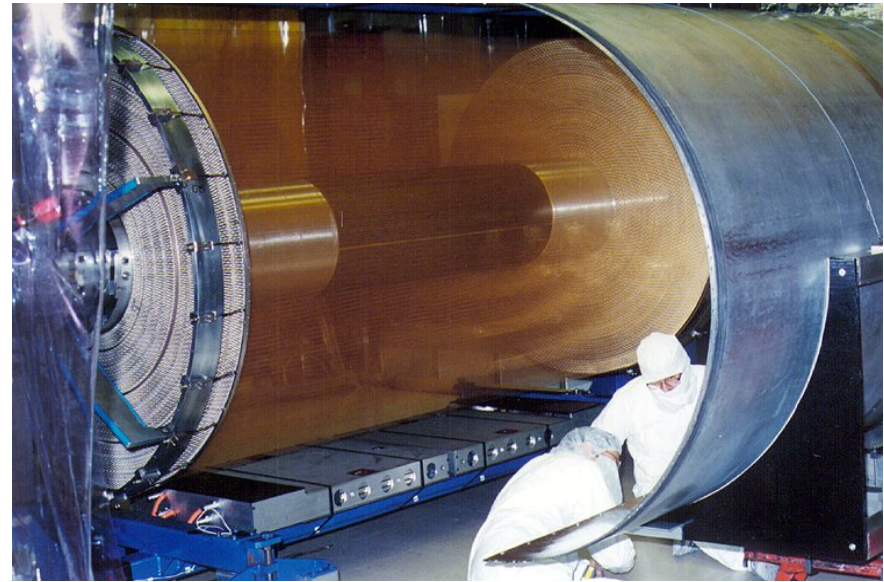
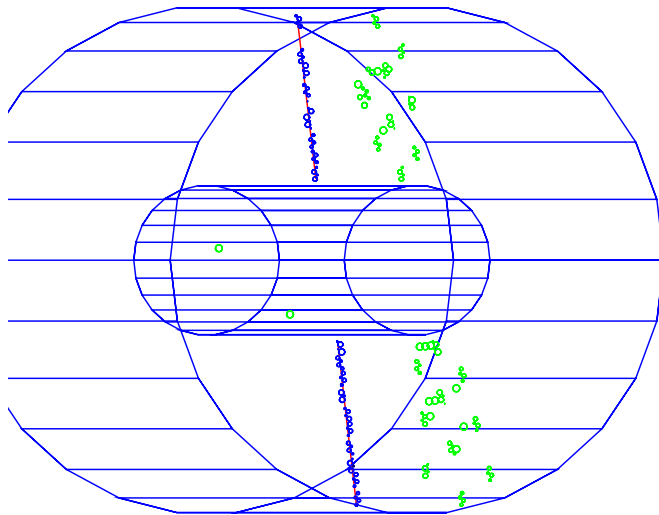



# Time Projection Chamber

## Ingredients:

- ❑ **Gas**  
E.g.: Ar + 10 to 20 % CH<sub>4</sub>
- ❑ **E-field**  
E ~ 100 to 200 V/cm
- ❑ **B-field**  
as big as possible to measure momentum  
to limit electron diffusion
- ❑ **Wire chamber**  
to detect projected tracks  
Timing gives z measurement
- ❑ **Long drift distances**  
~ metres

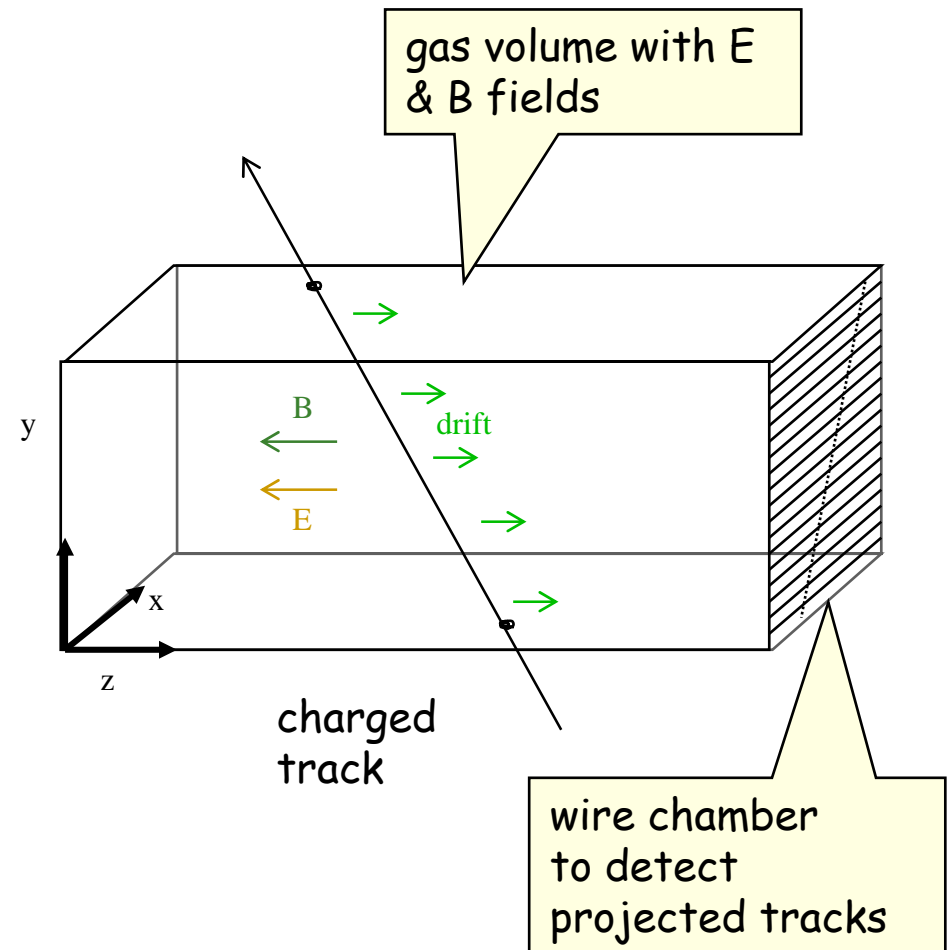

# Detector with TPC

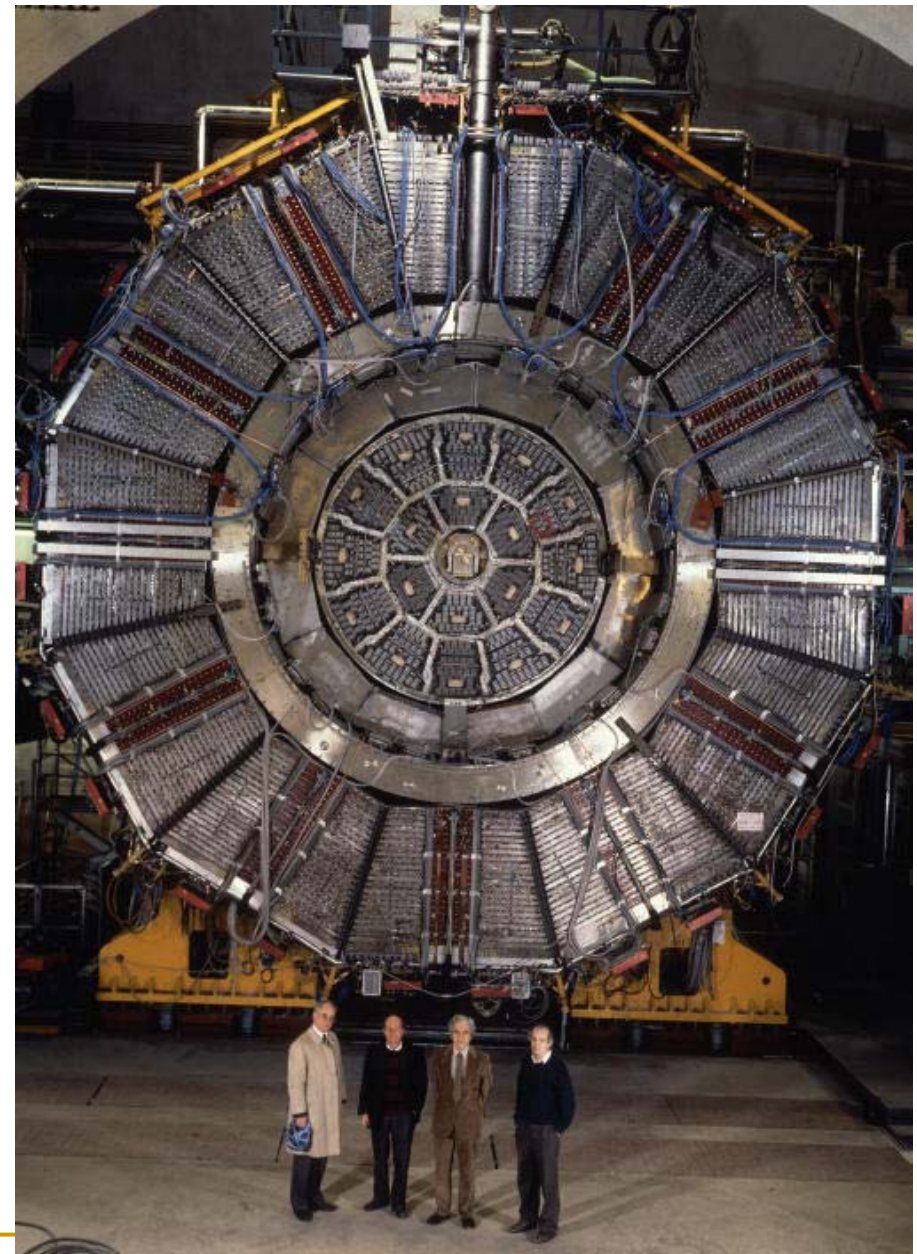
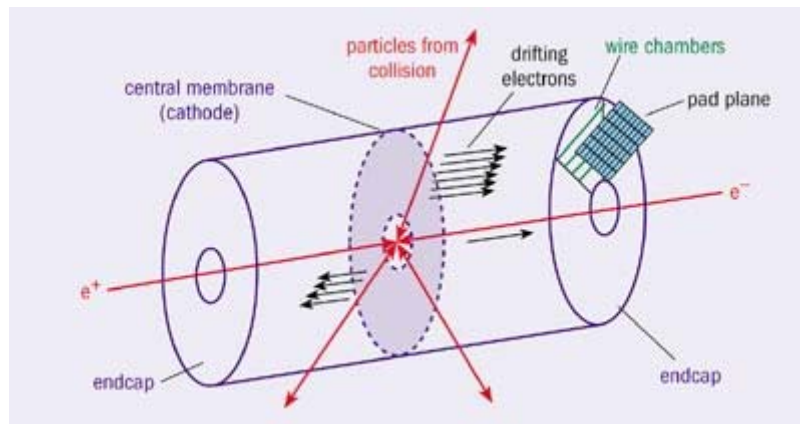
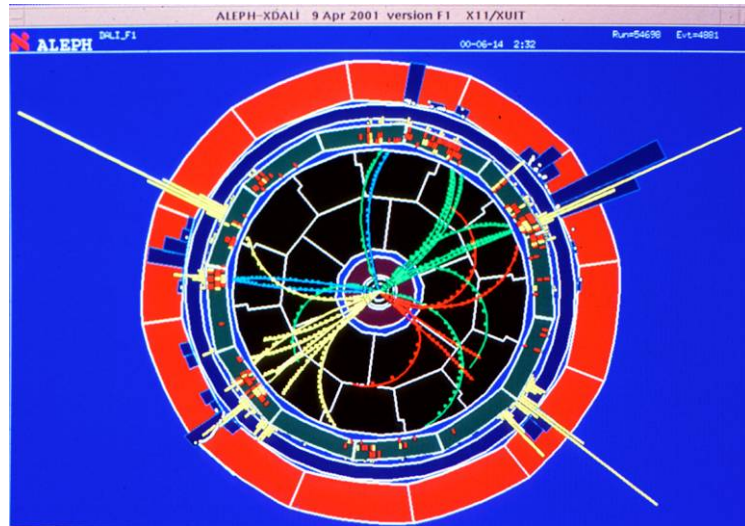

---

# General considerations for Wire Chambers

- Gas, voltage and geometry must be chosen carefully.
  - precision, amplification, avalanche characteristics...
  - Chambers can be damaged.
- External magnetic field influences behaviour.
  - **Must be measured and understood.**
- MWPC:
  - fast, reliable
  - often used for triggering
- Drift/TPC:
  - large volume, reasonably precise
  - **high incident fluxes can cause “short circuit”**
  - **long readout time**
- Need other solution for high rates and/or extreme precision

# Silicon Strip Detector

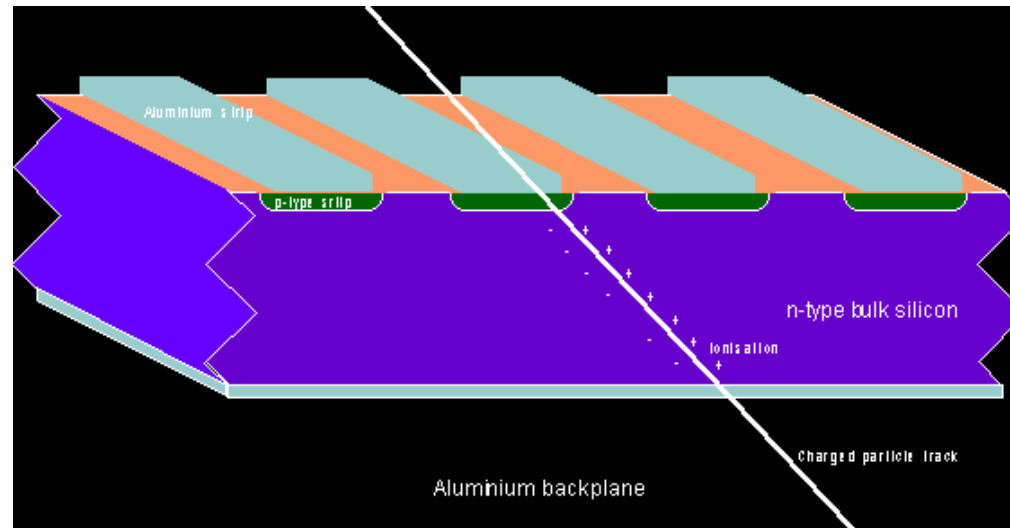

- Particle physics needs detectors which can determine the position of particles with an accuracy of 0.01 mm, have minimal thickness (0.3mm), and have very fast ( 0.000000025 second) time response.
- Silicon, a semiconductor, can be fabricated in two forms; n type, with a surplus of electron sites in the crystal lattice, and p type, with a deficit of electron sites in the crystal lattice.
- The majority of silicon detectors consist of n type bulk material. The back face has an aluminium contact over the complete surface. The front face has p type silicon strips implanted in the surface. These p type strips aluminium strips on their surface. The aluminium strips are separated from their associated p type silicon strips by a thin insulator. An electric field is applied between the p strips and the back face.
- When a charged particle passes through a silicon detector it creates ionisation in the bulk of the silicon. This frees electrons from the atoms of the silicon and leaving these atoms with an electron vacancy. These vacancies are referred to as "holes".
- The "holes" "drift" in the electric field towards the negatively charged p type strips. The electrons "drift" towards the positively charged back plane.
- When the "holes" reach the p type strip they are collected and induce a measurable charge on the associated aluminium strip. The aluminium strips are connected to sensitive electronic read out channels.
- By recording which electronic channel fired, it is possible to determine where the charged particle passed through the detector.

# Solid State Detectors

- Detect ionisation charges in solids
  - ❑ high density → large  $dE/dx$  signal
  - ❑ mechanically simple
  - ❑ can be very precise
- Semiconductors
  - ❑ small energy to create electron-hole pairs
  - ❑ silicon extremely widely used
    - band gap 1.1 eV
    - massive expertise and capability in electronics industry
- Resistors
  - ❑ plastic – cheap
  - ❑ diamond – robust, rad. hard
  - ❑ Germanium – can be made thin

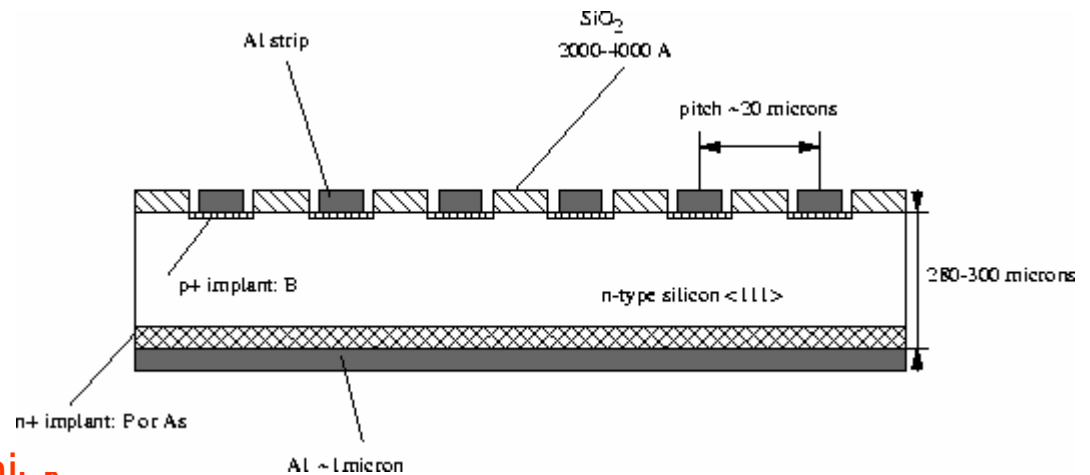
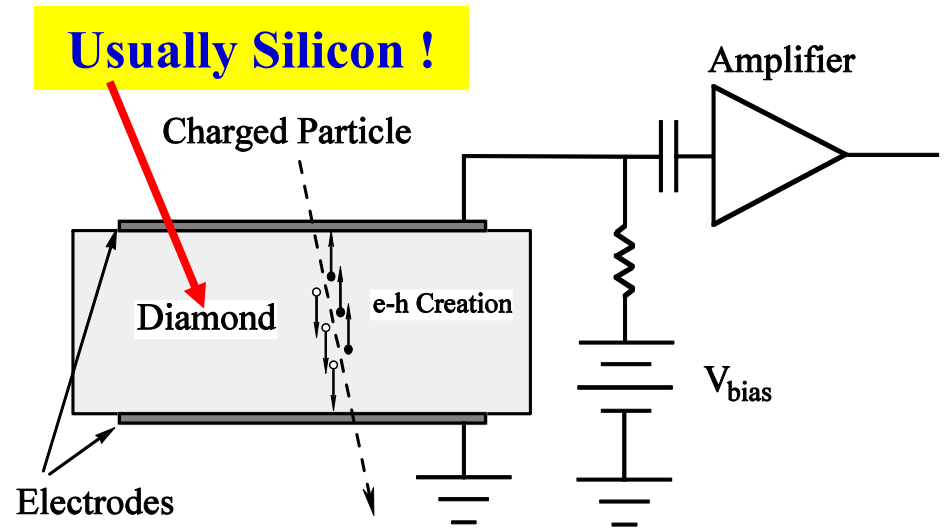



# Cerenkov Detector

## ■ Cerenkov Radiation

- speed of light in medium =  $c/n$
- $n$  = refractive index
- charged particles produce light “shock waves” if  $v > c/n$
- light cone  $\cos\theta = c/vn = 1/(n\beta)$
- “eerie blue glow”
- Useful for separating pions and kaons

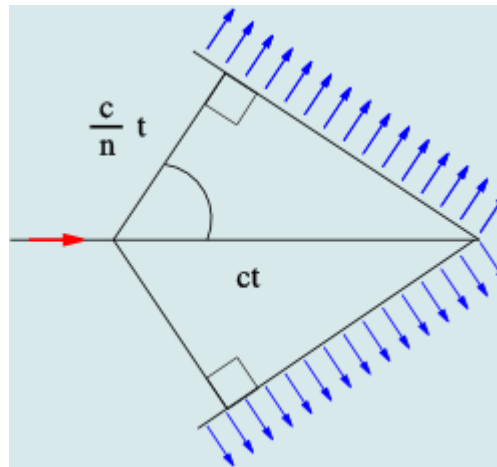
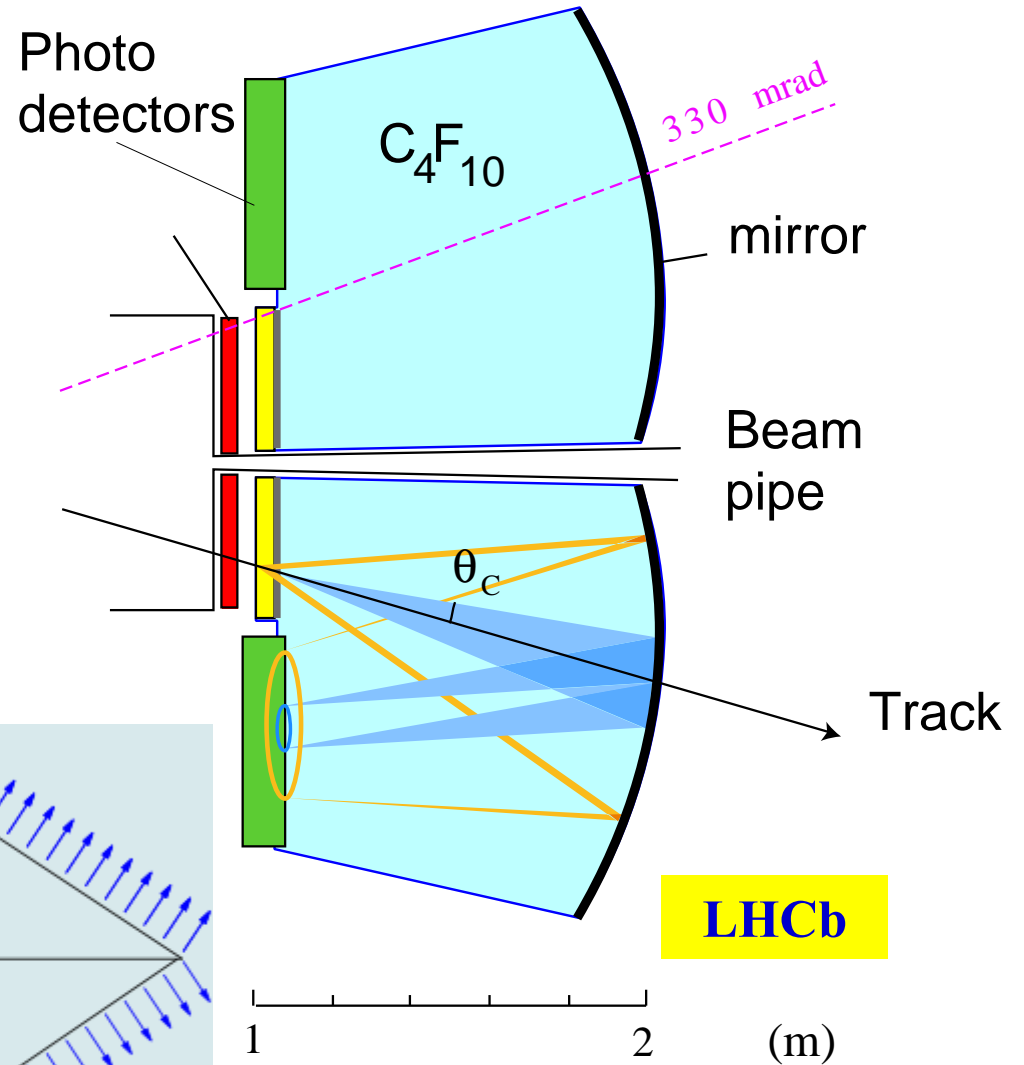

# Transition Radiation Detector

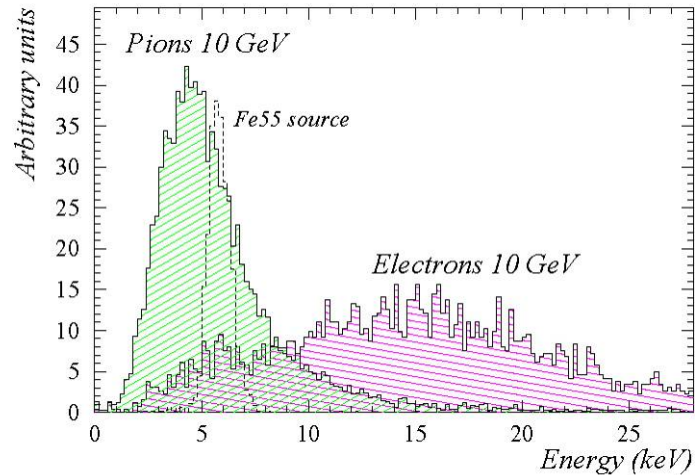

- An energetic charged particle moving through matter momentarily polarizes the material nearby. If the particle crosses a boundary where the index of refraction changes, the change in polarization gives rise to the emission of electromagnetic transition radiation.
- About one photon is emitted for every 100 boundaries crossed. Transition radiation is emitted even if the velocity of the particle is less than the light velocity of a given wavelength, in contrast to Cerenkov radiation. Consequently, this radiation can take place in the x-ray region of the spectrum where there is no Cerenkov radiation, because the index of refraction is less than one.
- At each interface between materials, the probability of transition radiation increases with the relativistic gamma factor. Thus particles with large  $\gamma$  give off many photons, and small  $\gamma$  give off few. For a given energy, this allows a discrimination between a lighter particle (which has a high  $\gamma$  and therefore radiates) and a heavier particle (which has a low  $\gamma$  and radiates much less).
- Useful for separating pions and electrons



---

Next Time...

*More interactions and detectors*