A complex visualization of particle tracks from a detector, likely a bubble chamber or cloud chamber. The tracks are numerous, thin lines radiating from a central point, colored in shades of blue, cyan, and red. The tracks are dense and fan out in all directions, creating a starburst pattern. The background is black, and the tracks are overlaid on a faint grid.

Experimental Particle Physics PHYS6011  
Southampton University 2009  
Lecture 1

Fergus Wilson,  
Email: [Fergus.Wilson@stfc.ac.uk](mailto:Fergus.Wilson@stfc.ac.uk)

---

# Administrative Points

- 5 lectures:
  - 12am : 22<sup>nd</sup>, 27<sup>th</sup>, 29<sup>th</sup> April and 6<sup>th</sup> May
  - 4pm: 7<sup>th</sup> May
- Course Objectives, Lecture Notes, Problem examples:
  - <http://hepwww.rl.ac.uk/fwilson/Southampton>
- Resources:
  - K. Wille, “The Physics of Particle Accelerators”
  - D. Green, “The Physics of Particle Detectors”
  - K.Kleinknecht, “Detectors for Particle Radiation”
  - I.R. Kenyon, “Elementary Particle Physics” (chap 3).
  - Martin and Shaw, “Particle Physics”
  - Particle Data Group, <http://pdg.lbl.gov>

---

# Syllabus

1. Accelerators and Sources
2. Interactions with Matter
3. Detectors
4. A modern particle physics experiment
5. How an analysis is performed.

# Natural Units

- Natural Units:
  - Energy - GeV
  - Mass – GeV/c<sup>2</sup>
  - Momentum – GeV/c
  - Length and time – GeV<sup>-1</sup>
- Use the units that are easiest.
- 1 eV = 1.602 x 10<sup>-19</sup> J

$$\hbar = c = 1$$

$$E^2 = p^2 c^2 + m^2 c^4$$

$$\Rightarrow E^2 = p^2 + m^2$$

# Introduction

- Time, energy (temperature) and distance are related:

- High momentum  $\Leftrightarrow$
- Small distance  $\Leftrightarrow$
- High temperature  $\Leftrightarrow$
- Early Universe

$$T_{univ} (K) = 1.5 \times 10^{12} t^{-2/3} \quad t < 10^{11} \text{secs}$$

$$T_{univ} (K) = 2 \times 10^{10} t^{-1/2} \quad t > 10^{11} \text{secs}$$

Boltzmann constant,  $k = 8.619 \times 10^{-5} \text{ eV K}^{-1}$

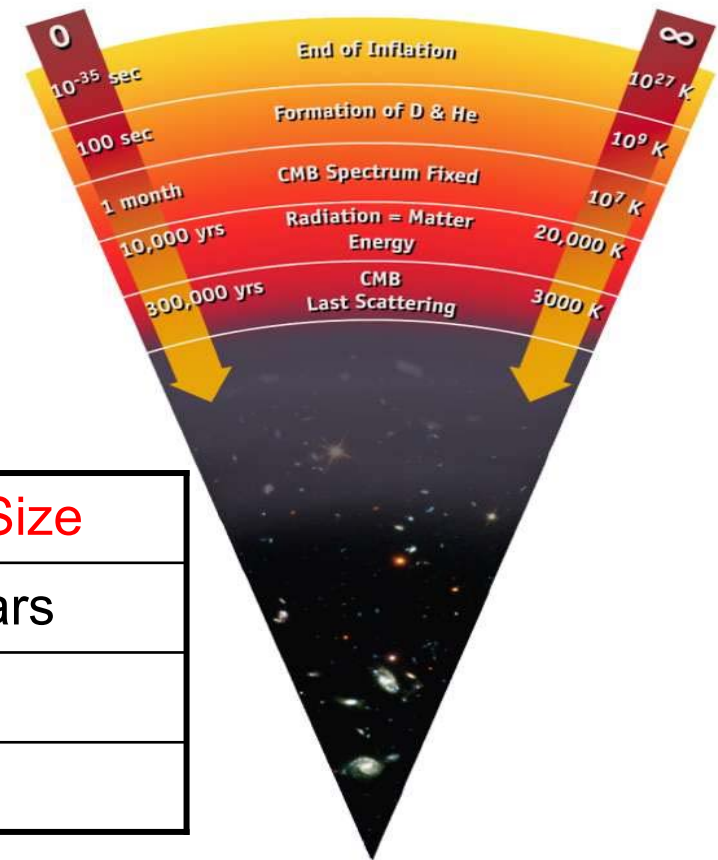

Energy	Age (secs)	Temp. (K)	Observable Size
1 eV	$10^{13}$	$10^4$	$10^6$ Light Years
1 MeV	1	$10^{10}$	$10^6$ km
10 TeV	$10^{-14}$	$10^{17}$	$10^{-2}$ mm

# History of the Universe

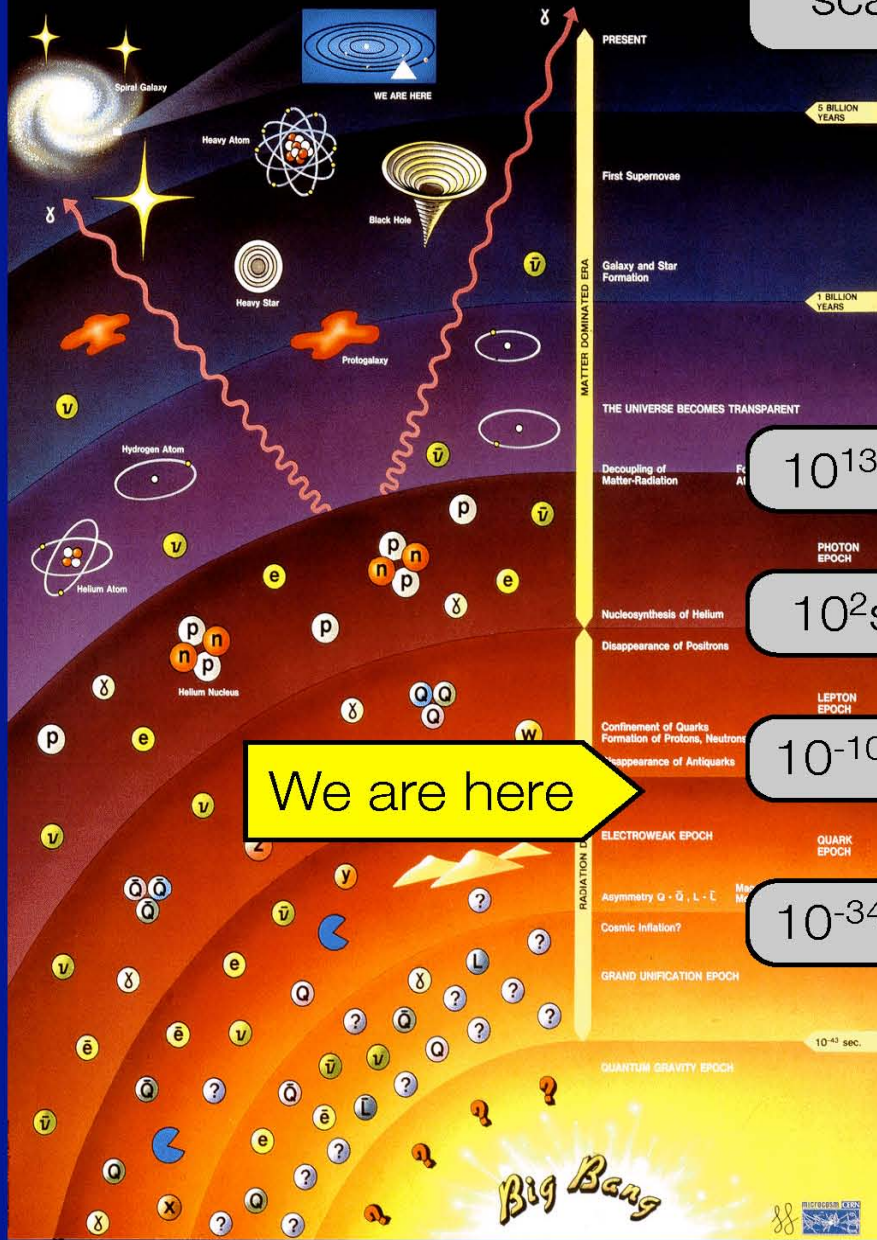

We are here

time scale

energy scale

Electroweak Epoch

Higgs particles

Supersymmetry

Unification Epoch

Grand unification of fundamental forces

Origin of Neutrino mass (RH neutrino)

Leptogenesis (baryogenesis)

Quantum Gravity Epoch

$10^{19}$  GeV

Superstrings

# Natural Radioactivity

- First discovered in late 1800s
- Used as particle source in many significant experiments
  - Rutherford's 1906 experiment: elastic scattering  $\alpha + N \rightarrow \alpha + N$
  - Rutherford's 1917 experiment: inelastic scattering  $\alpha + N \rightarrow p + X$
- Common radioisotopes include
  - $^{55}\text{Fe}$ : 6 keV  $\gamma$ ,  $\tau_{1/2} = 2.7$  years
  - $^{90}\text{Sr}$ : 500 keV  $\beta$ ,  $\tau_{1/2} = 28.9$  years
  - $^{241}\text{Am}$ : 5.5 MeV  $\alpha$ ,  $\tau_{1/2} = 432$  years
  - $^{210}\text{Po}$ : 5.41 MeV  $\alpha$ ,  $\tau_{1/2} = 137$  days
- Easy to control, predictable flux but low energy
- Still used for calibrations and tests

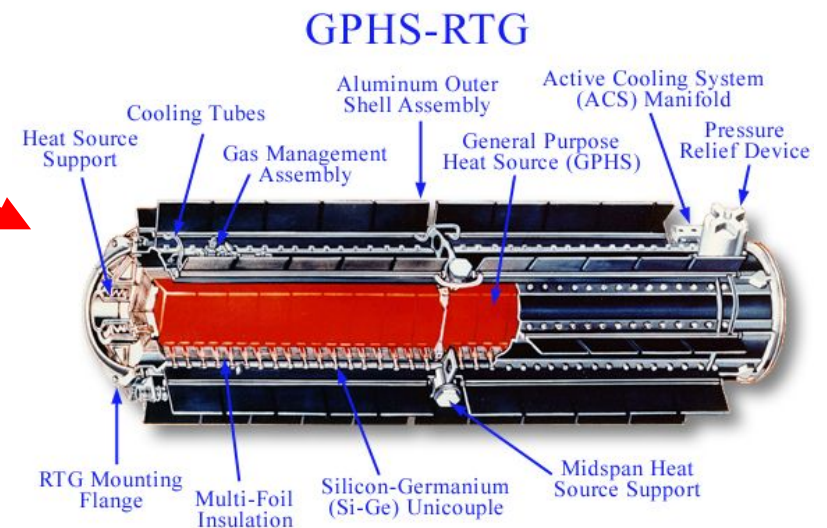

# Cosmic Rays

- History
  - ❑ 1912: First discovered
  - ❑ 1927: First seen in cloud chambers
  - ❑ 1962: First  $10^{20}$  eV cosmic ray seen
- Low energy cosmic rays from Sun
  - ❑ Solar wind (mainly protons)
  - ❑ Neutrinos
- High energy particles from sun, galaxy and perhaps beyond
  - ❑ **Primary: Astronomical sources.**
  - ❑ **Secondary: Interstellar Gas.**
  - ❑ Neutrinos pass through atmosphere and earth
  - ❑ Low energy charged particles trapped in Van Allen Belt
  - ❑ High energy particles interact in atmosphere.
  - ❑ Flux at ground level mainly muons:  $100\text{-}200\text{ s}^{-1}\text{ m}^{-2}$
- Highest energy ever seen  $\sim 10^{20}\text{eV}$

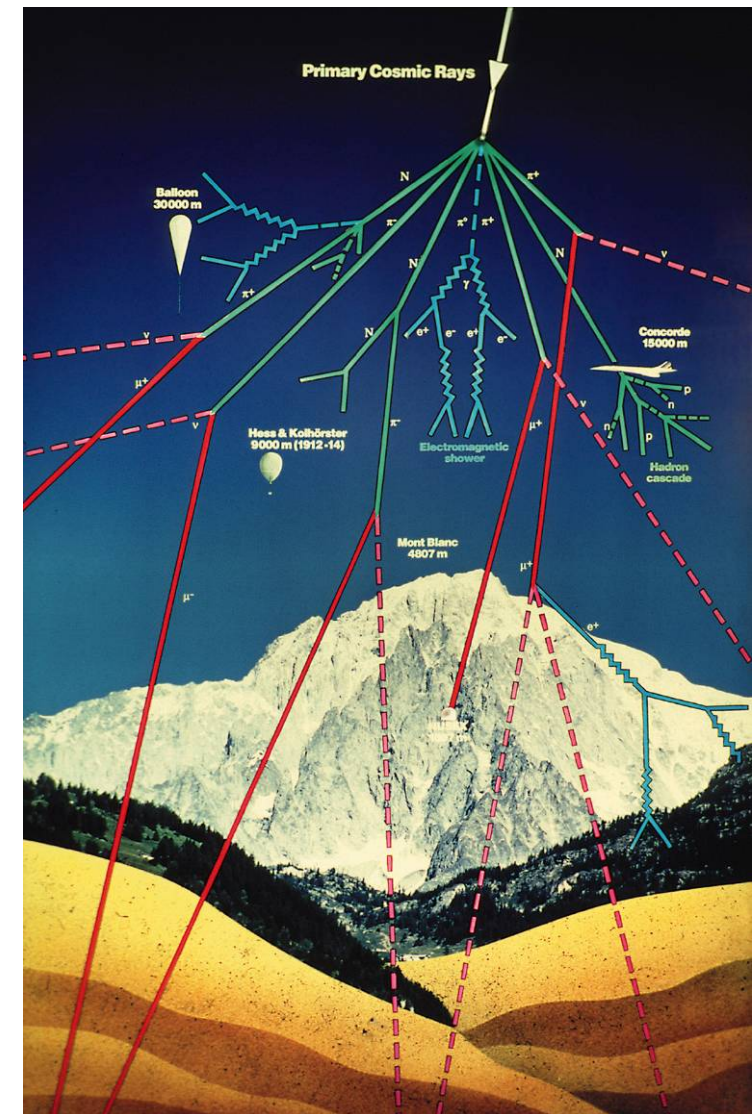



# Cosmic Rays

$$I_N(E) \approx 1.8E^{-2.7} \frac{\text{nucleons}}{\text{cm}^2 \text{s sr GeV}} \quad E < 100\text{TeV}$$

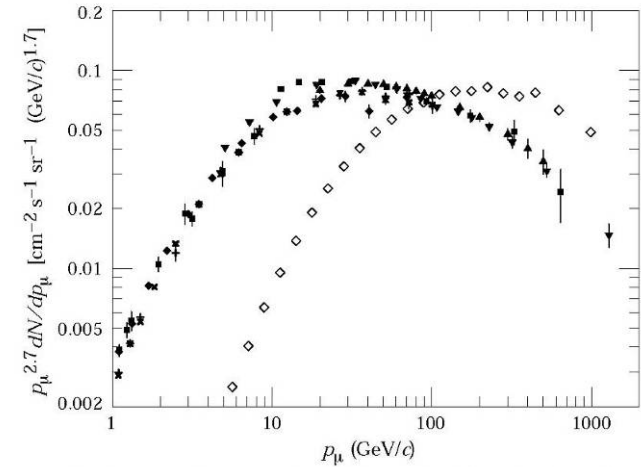
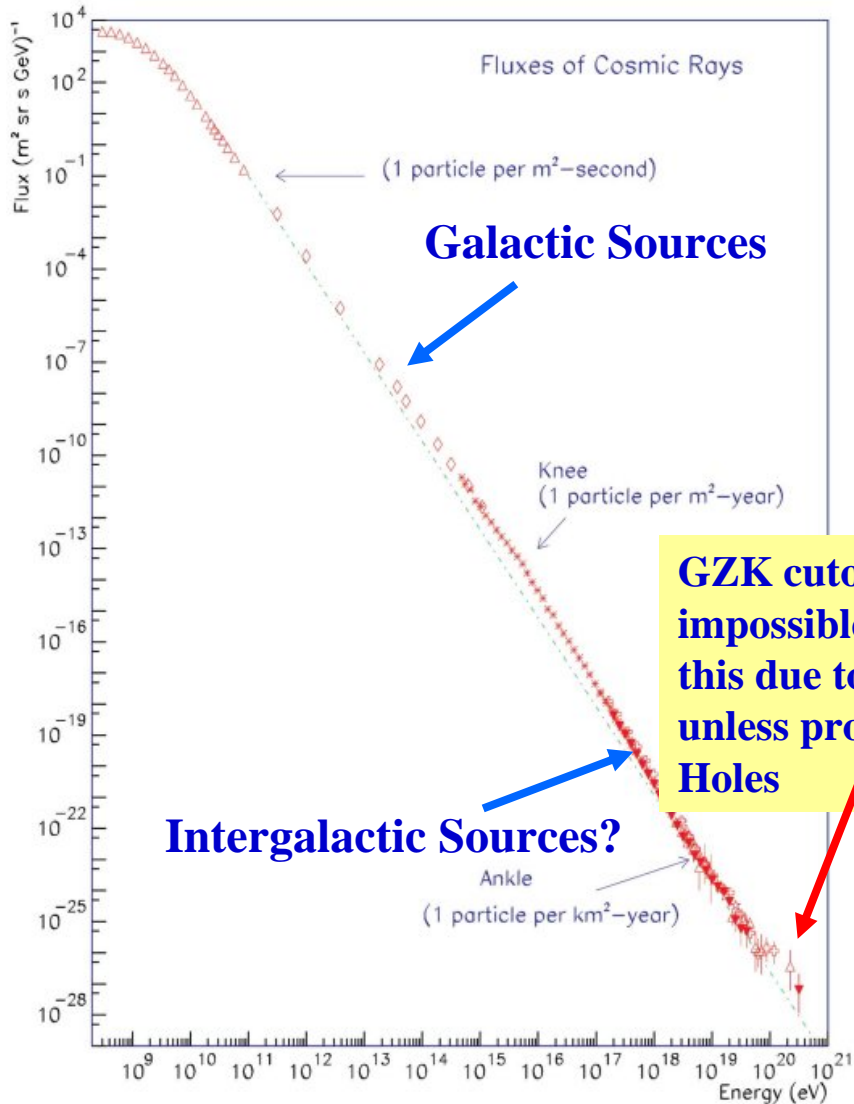
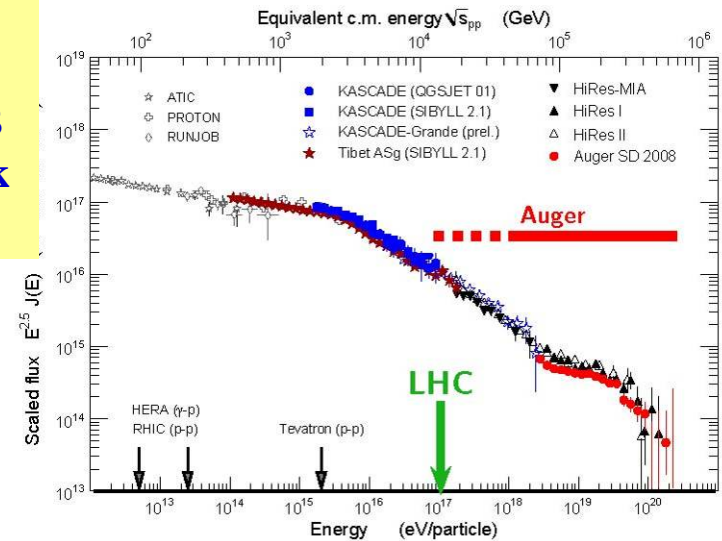
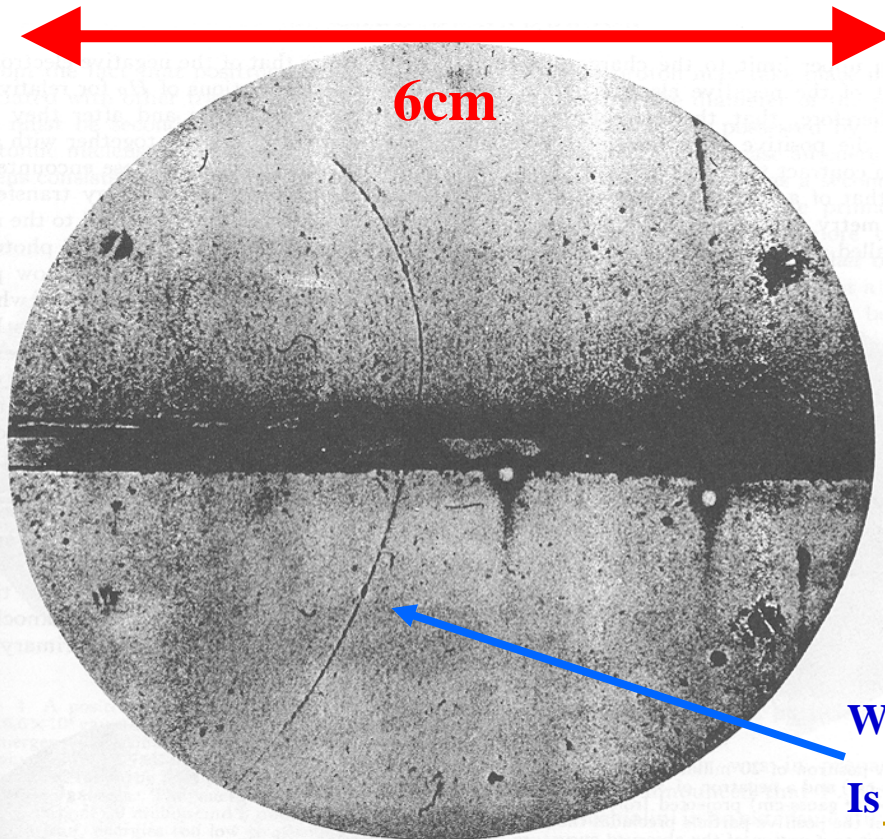

Figure 24.4: Spectrum of muons at  $\theta = 0^\circ$  ( $\blacklozenge$  [29],  $\blacksquare$  [34],  $\blacktriangledown$  [35],  $\blacktriangle$  [36],  $\times$  and  $+$  [31], and  $\theta = 75^\circ$   $\diamond$  [37]).



# Cosmic Ray Experiments

- Primary source for particle physics experiments for decades
- Detectors taken to altitude for larger flux/higher energy
- Positron and many other particles first observed



Modern experiments include:

- Particle astrophysics
    - Space, atmosphere, surface, underground
  - Neutrino
    - Solar, atmospheric
  - “Dark Matter” searches
- Still useful for calibration and testing

Which direction is the  $e^+$  moving (up or down)?

Is the B-field in or out of the page?

# Cosmic Rays - Pierre Auger Project

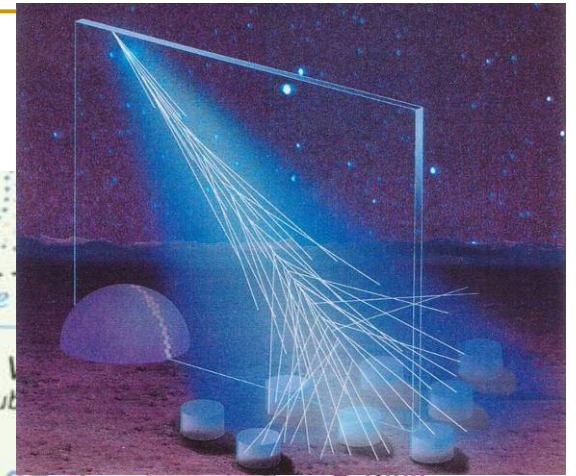
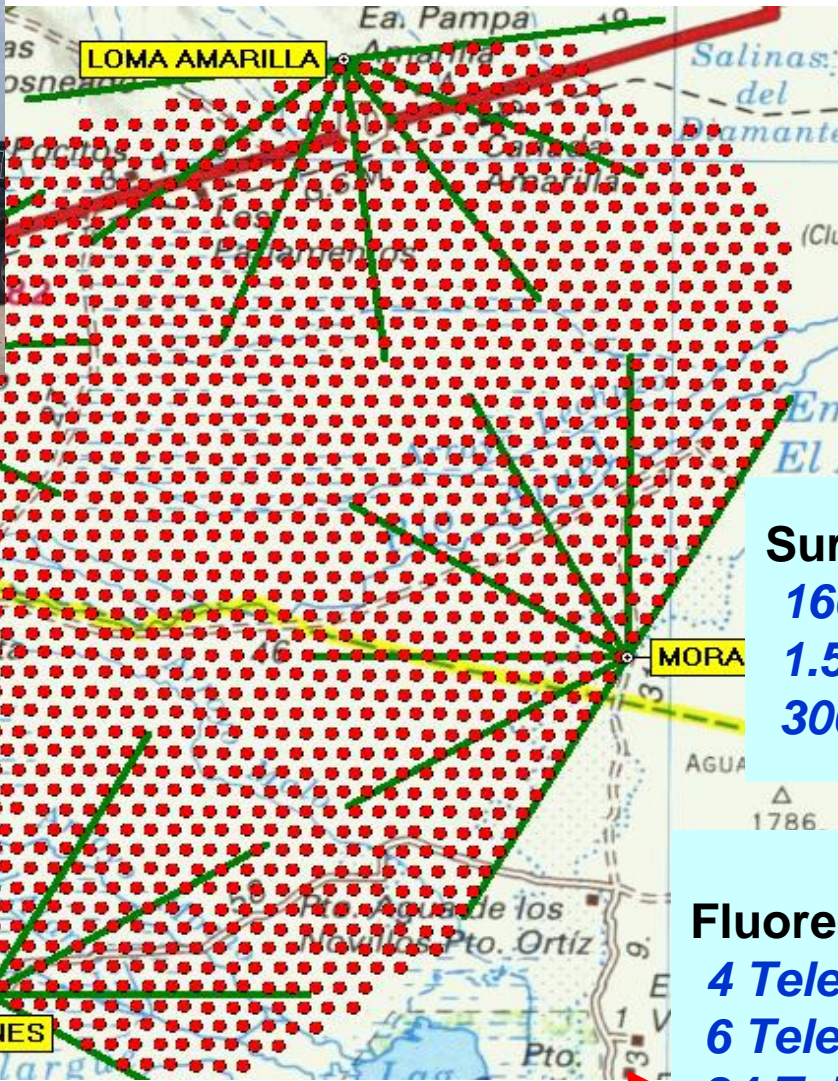

**Surface Array**  
1600 detector stations  
1.5 km spacing  
3000 km<sup>2</sup>

**Fluorescence Detectors**  
4 Telescope enclosures  
6 Telescopes per enclosure  
24 Telescopes total

22nd April 2009

60 km

Fergus Wilson, RAL

# Dark Energy and Dark Matter

- Most of the Universe is invisible.
- Dark Energy:
  - Exerts a negative pressure on the Universe
  - Increases the acceleration of the galaxies.
- Dark Matter:
  - Just like ordinary matter but not visible (does not give off light).
- 1: Baryonic Dark Matter
  - ~2% of the Universe
  - MACHOS, dwarf stars, etc...
- 2: Non-Baryonic Dark Matter
  - ~20% of the Universe
  - Hot (neutrinos) and Cold (WIMPS, axions, neutralinos).
  - Expected to be mostly Cold

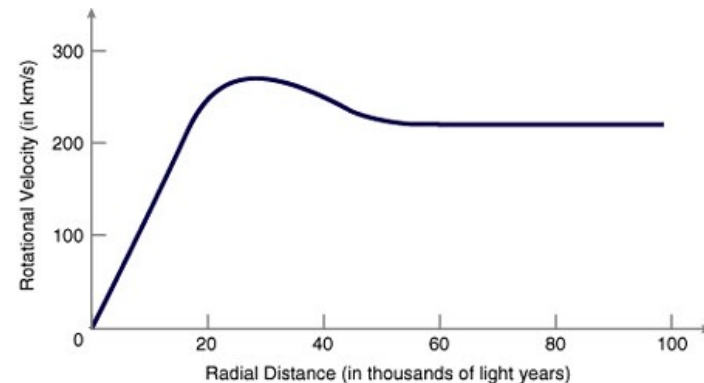
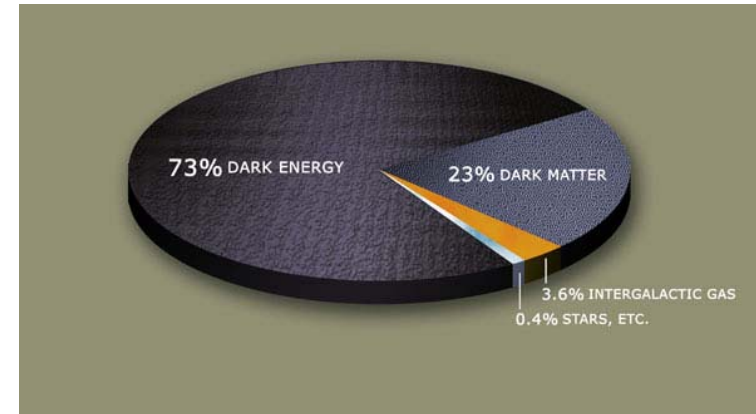

$$\text{Rotation Velocity } v(r) = \sqrt{\frac{M(r)}{r}}$$
$$\text{Outside Galaxy } v(r) \propto \frac{1}{\sqrt{r}}$$

# Dark Matter - DAMA

<http://people.roma2.infn.it/~dama>

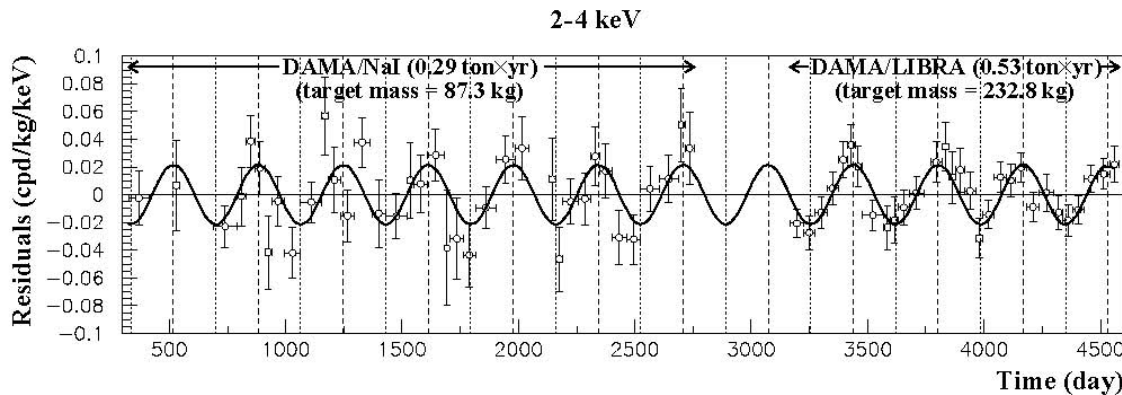
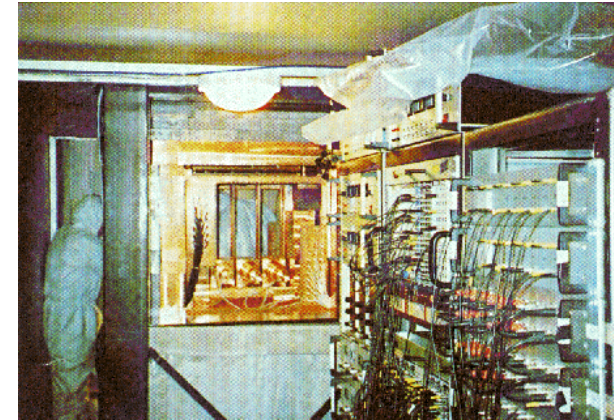
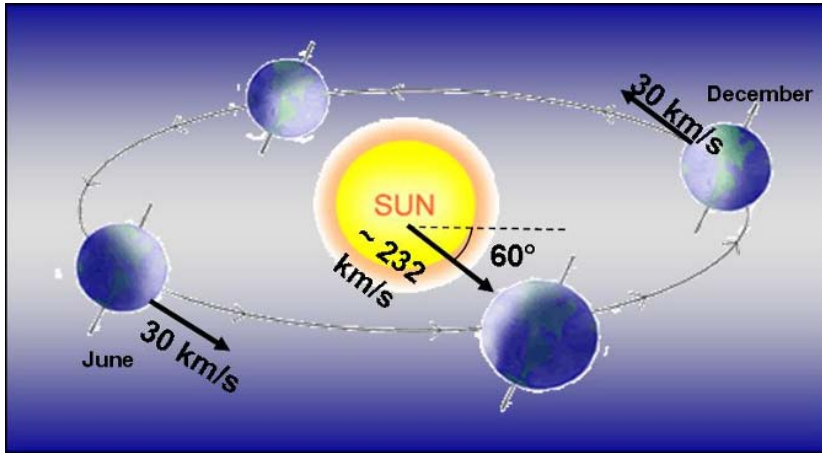

<http://arxiv.org/abs/0804.2741>

1. As the earth goes round the sun, its velocity relative to the galaxy changes by +/-30 km
2. Look for nuclear recoil in NaI as nucleus interacts with “dark matter” particle.
3. Expect to see a change in the rate of interactions every six months
4. But is there really a pattern? and is it really dark matter?

# Neutrinos – Nuclear Reactors and the Sun

- Reactors – Nuclear Fission
- Sun – Nuclear Fusion
- But still weak interactions. Well understood.
- Huge fluxes of MeV neutrons and electron neutrinos.
- But low energy.
- First direct neutrino observation in 1955.

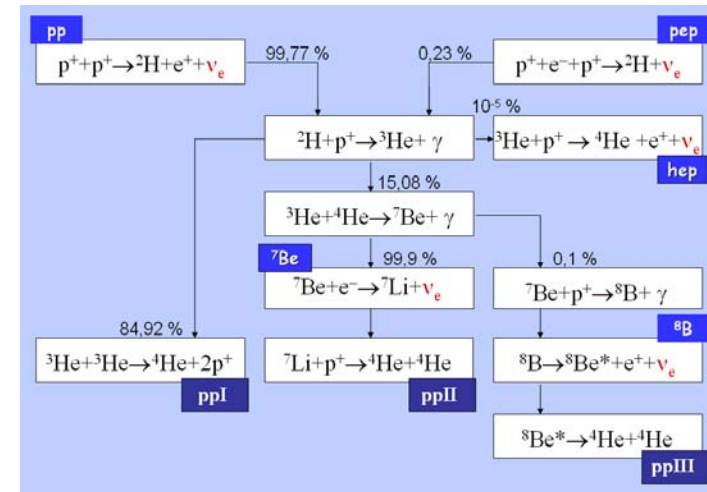

Neutrino density at Earth  $\sim 5 \times 10^6 \text{ cm}^{-2} \text{ s}^{-1}$

Mean free path  $d$  :

$$d \approx \frac{u}{\sigma \rho} = \frac{1.66 \times 10^{-27} \text{ kg}}{(10^{-47} \text{ m}^2)(\rho \text{ kg/m}^3)}$$

$$\Rightarrow d_{\text{water}} = 18 \text{ light years}$$

# Neutrino Oscillation

$$|\nu_\alpha\rangle = \sum_{i=1}^3 U_{\alpha i}^* |\nu_i\rangle$$

$\alpha$  = neutrino with definite flavour (e,  $\mu$ ,  $\tau$ )

$i$  = neutrino with definite mass (1,2,3)

$$P_{\nu_\alpha \rightarrow \nu_\beta} = \sin^2 2\theta \sin^2 \left( 1.267 \frac{\Delta m^2 L}{E} \frac{\text{GeV}}{\text{eV}^2 \text{km}} \right)$$

$$\Delta m_{21}^2 = \Delta m_{\odot}^2 = (8.0_{-0.4}^{+0.6}) \times 10^{-5} \text{ eV}^2$$

$$\theta_{21} = \theta_{\odot} = (33.9_{-2.2}^{+2.4})^\circ$$

$$\Delta m_{32}^2 = \Delta m_{atm}^2 = (2.4_{-0.5}^{+0.6}) \times 10^{-3} \text{ eV}^2$$

$$\theta_{32} = \theta_{atm} = (45 \pm 7)^\circ$$

$$\theta_{31}, \Delta m_{31}^2 = \text{unknown}$$

- Neutrinos “Oscillate”:
- Can change from one type to another.
- Implies  $\nu$  have mass.
- Oscillation experiments can only measure difference in squared mass  $\Delta m^2$

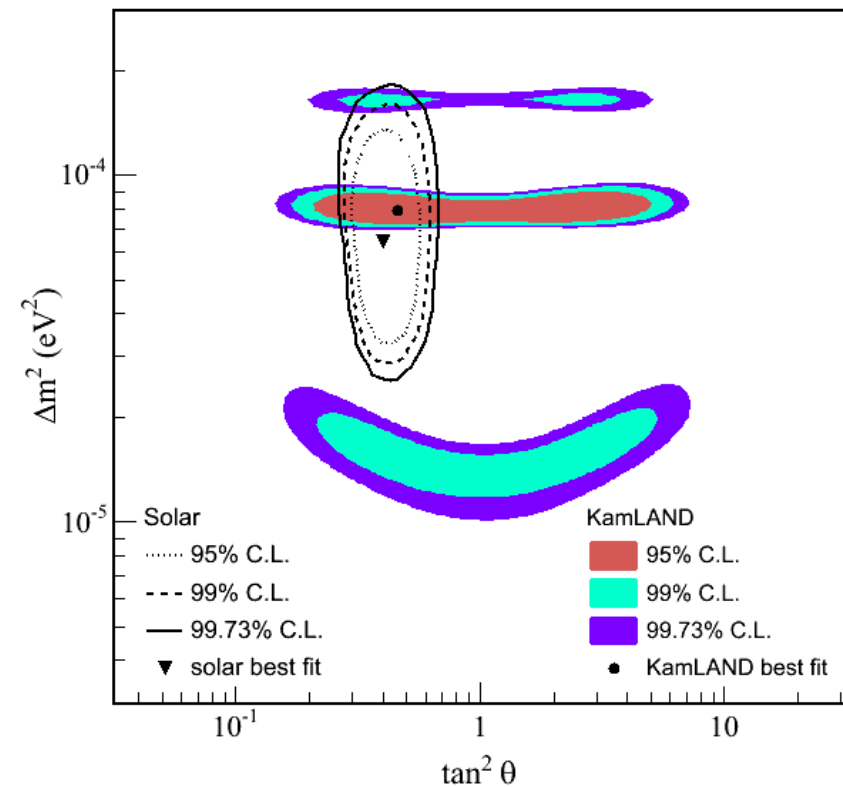

# Some Neutrino Detectors – Present and Future

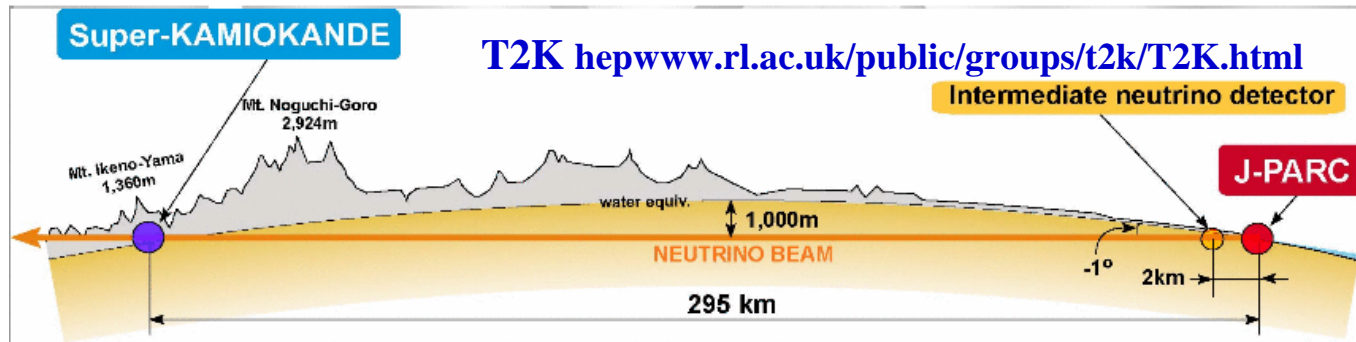

**Super-Kamiokande**  
<http://www-sk.icrr.u-tokyo.ac.jp/>

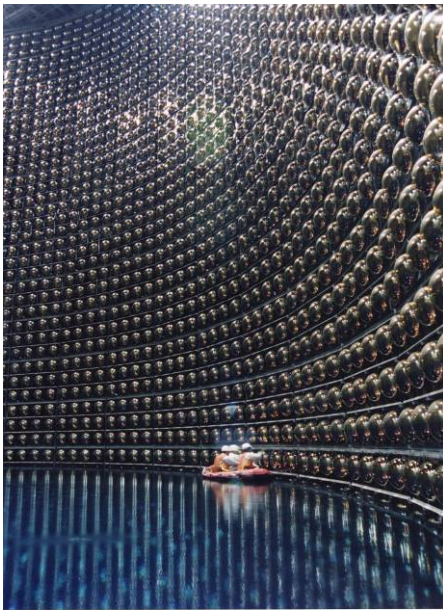

**Antares**  
<http://antares.in2p3.fr>



**Ice Cube**  
<http://icecube.wisc.edu/>

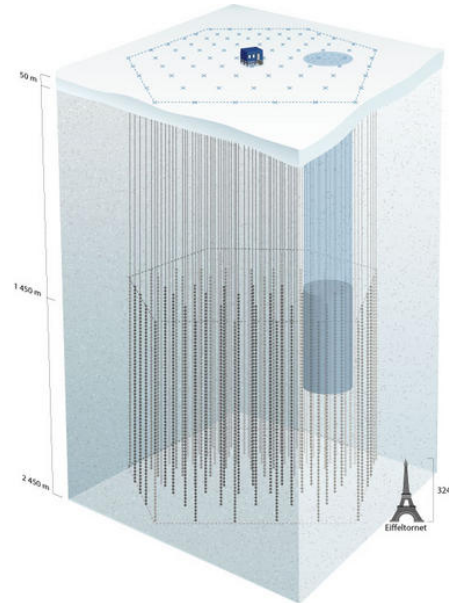

**KM3NeT**  
<http://www.km3net.org>

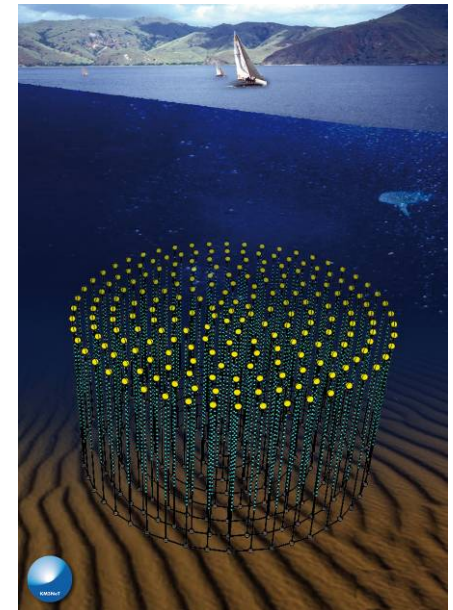



# Particle Sources

Want intense monochromatic beams on demand:

1. Make some particles
  - Electrons: metal + few eV of thermal energy
  - Protons/nuclei: completely ionise gas
2. Accelerate them in the lab

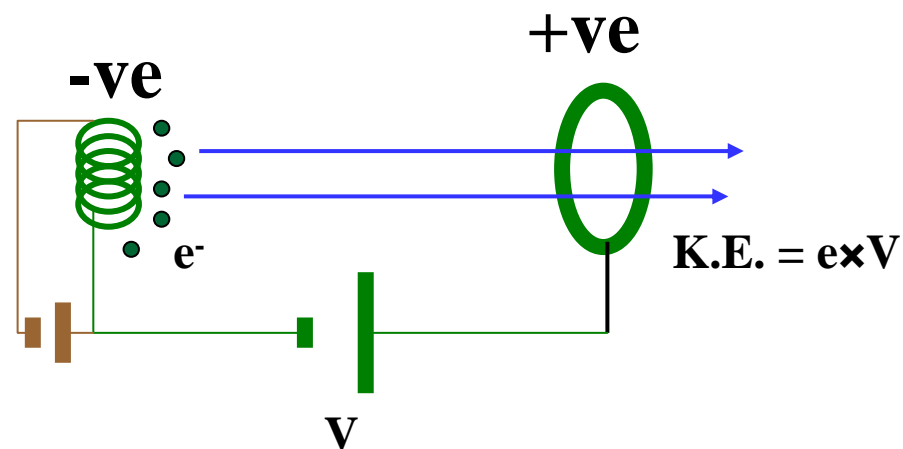

# Creating Electrons

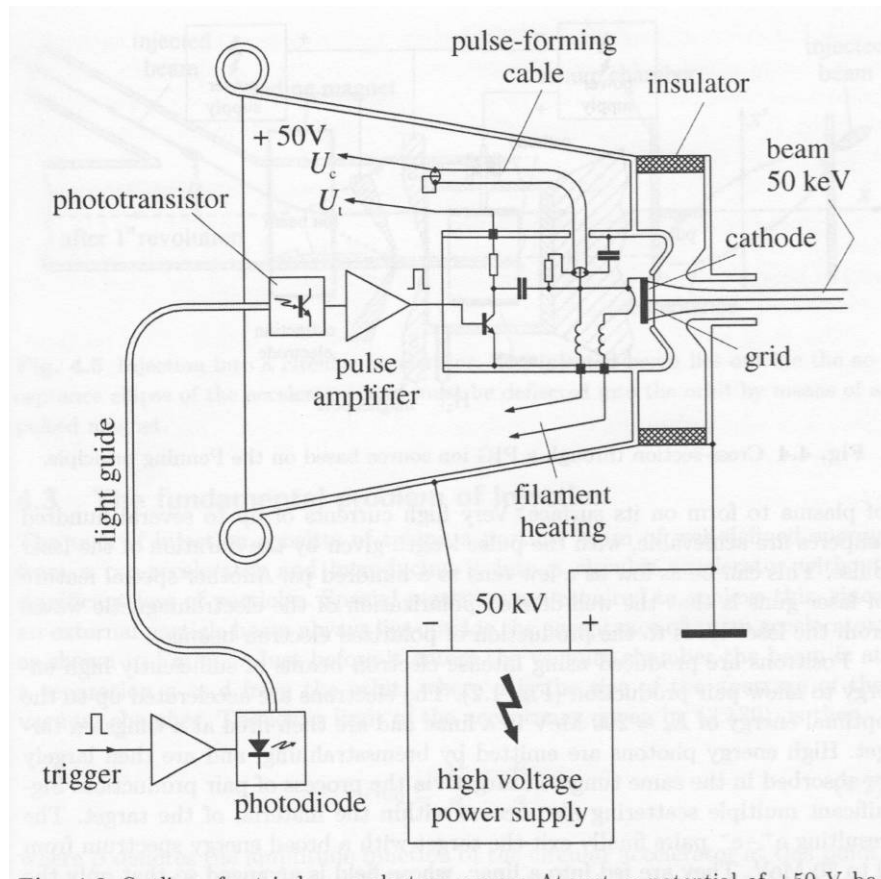

- Triode Gun
- Current: 1 A
- Voltage: 50 kV
- Cathode is held at 50V above anode (so no electrons escape).
- When triggered, cathode voltage reduced to 0V. Electrons flow through grid.
- Pulse length: ~1ns

# Creating Positrons

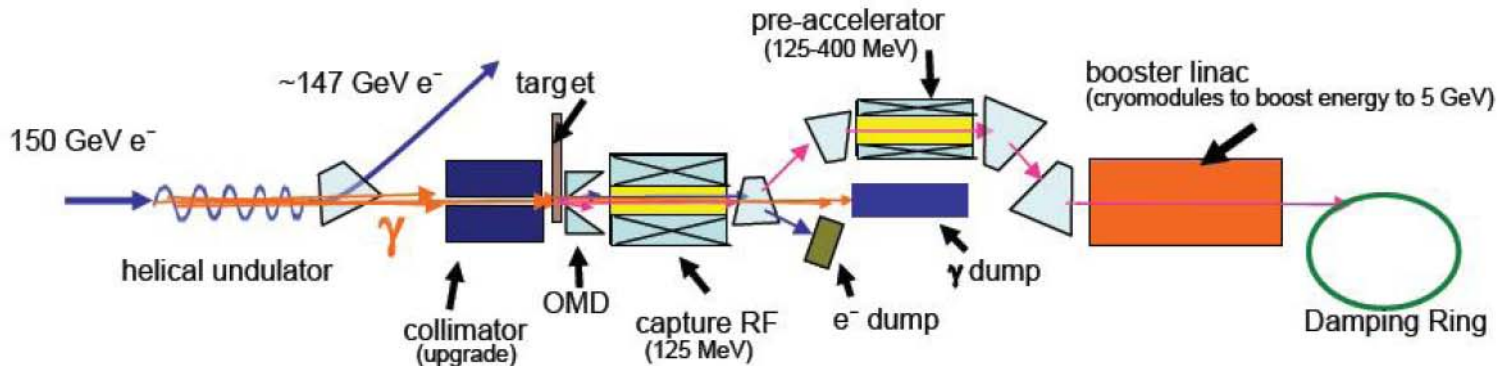

Example of how it will be done at the ILC

- High energy  $e^-$  emit photons in undulator.
- Photons hit target (tungsten)
- Positrons and electrons emitted by pair-production.
- Electrons removed, positrons accelerated.
- Inefficient: 1 positron for every  $10^5$  high energy electrons.

Example of how it is done at SLAC

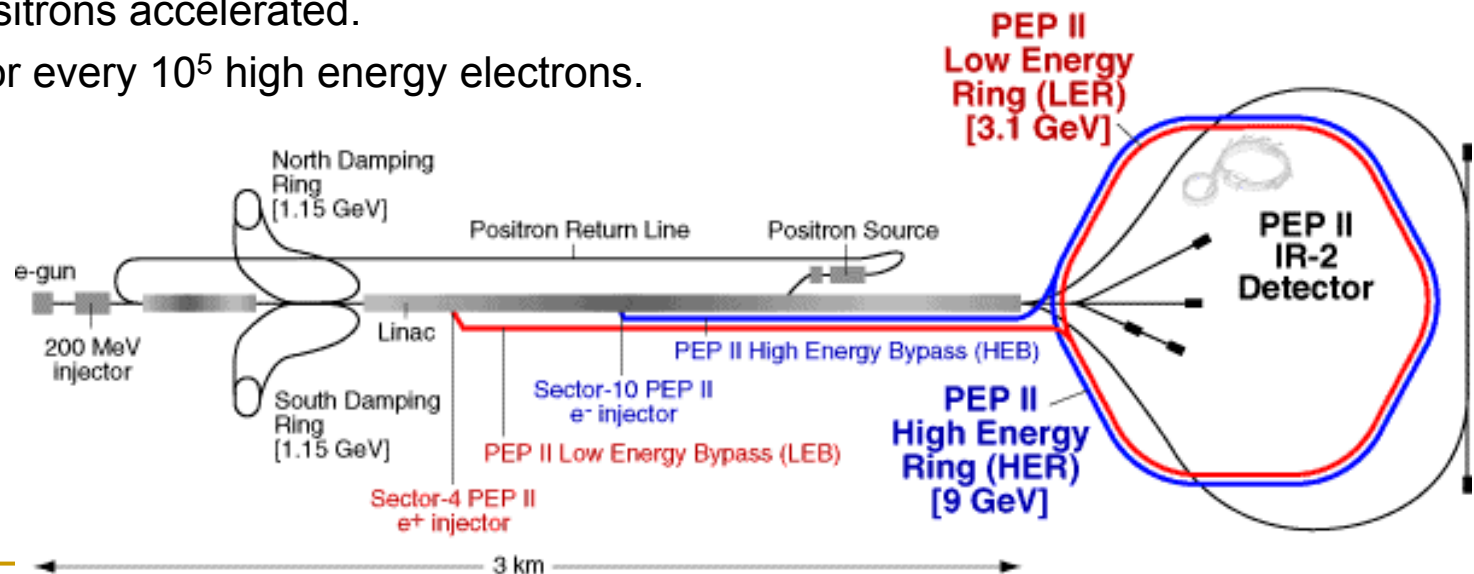

# Creating Protons – PIG (Penning Ion Gauge)

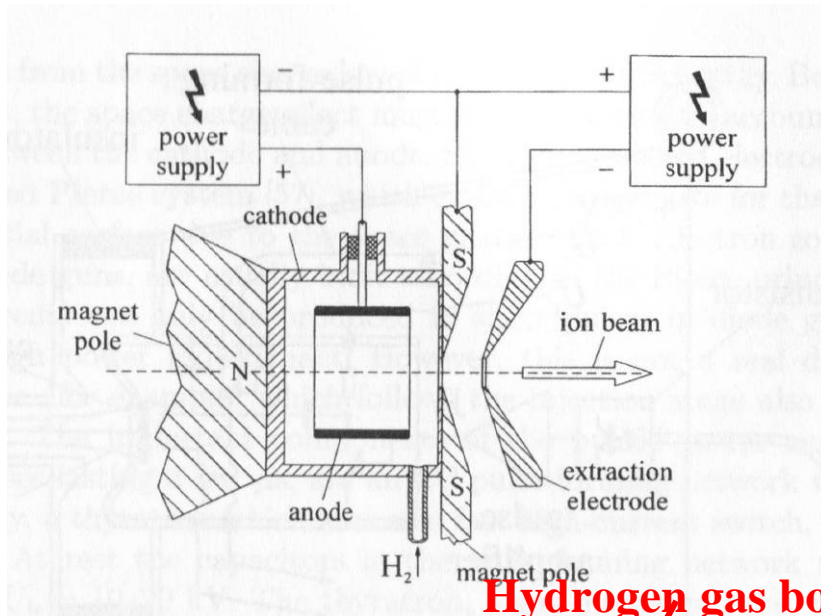

Hydrogen gas bottle

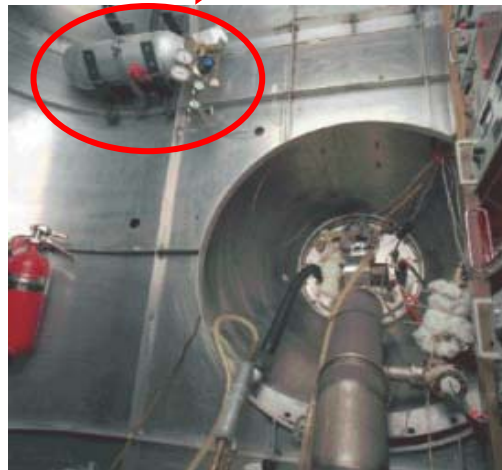

**Tevatron**

- Ion source (e.g. H<sub>2</sub>) introduced as a gas and ionised.
- Magnetic field 0.01T perpendicular to E-field causes ions to spiral along B-field lines.
- Low pressure needed to keep mean-free path long (10<sup>-3</sup> Torr).
- Modern methods are more complicated.

# Anti-Proton Production at CERN

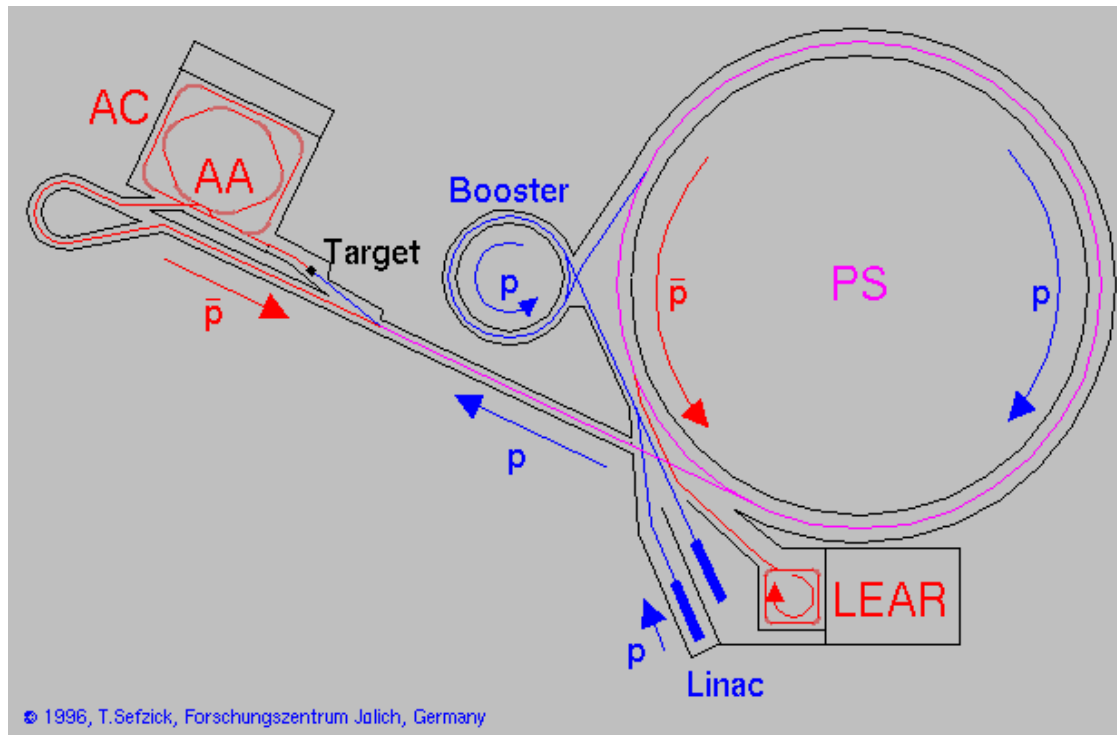

Protons are accelerated in a linear accelerator, booster, and proton synchrotron (PS) up to 27 GeV. These protons hit a heavy target (Beryllium). In the interaction of the protons and the target nuclei many particle-antiparticle pairs are created out of the energy, in some cases proton-antiproton pairs. Some of the antiprotons are caught in the antiproton cooler (AC) and stored in the antiproton accumulator (AA). From there they are transferred to the low energy antiproton ring (LEAR) where experiments take place.

# DC Accelerators – Cockcroft Walton

## How it works

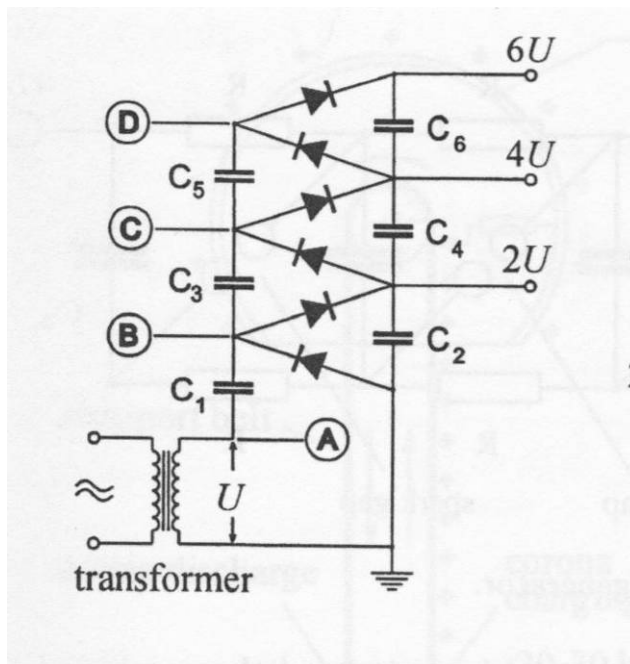

## Cockcroft and Walton's Original Design (~1932)

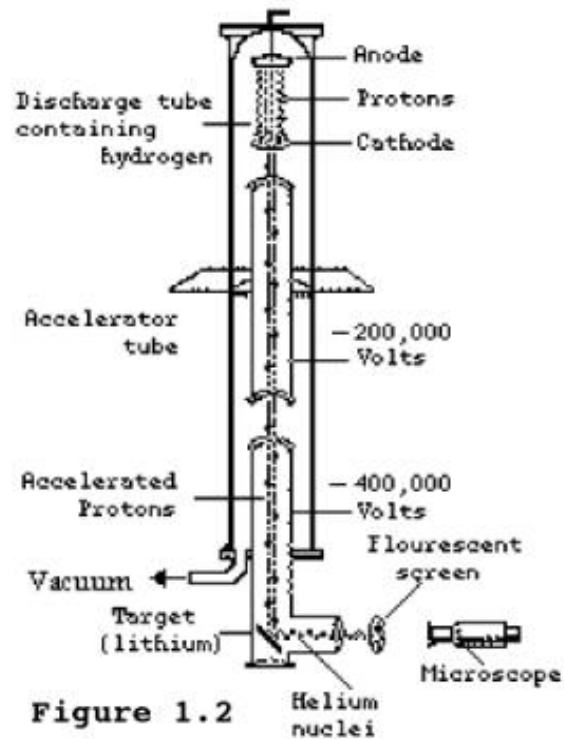

## Fermilab's 750kV Cockcroft-Walton

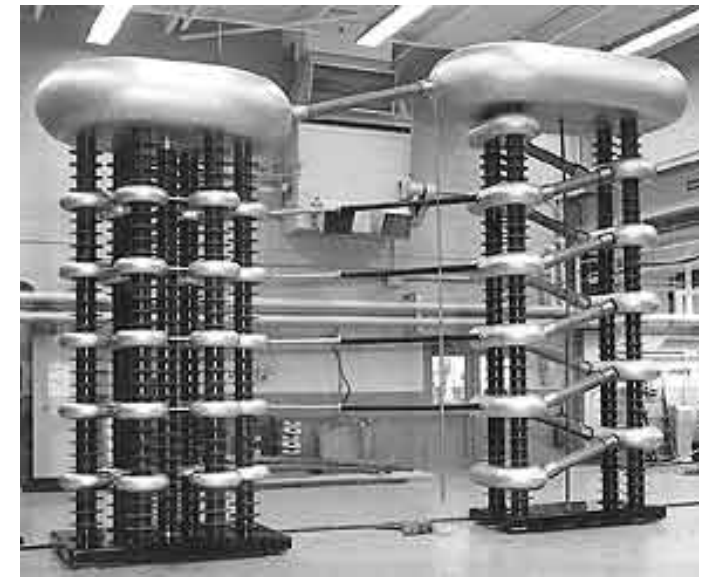

- DC accelerators quickly become impractical
- Air breaks down at  $\sim 1$  MV/m

# DC Accelerators – Van der Graaff

**Van de Graaf at MIT**

**(25 MV)**

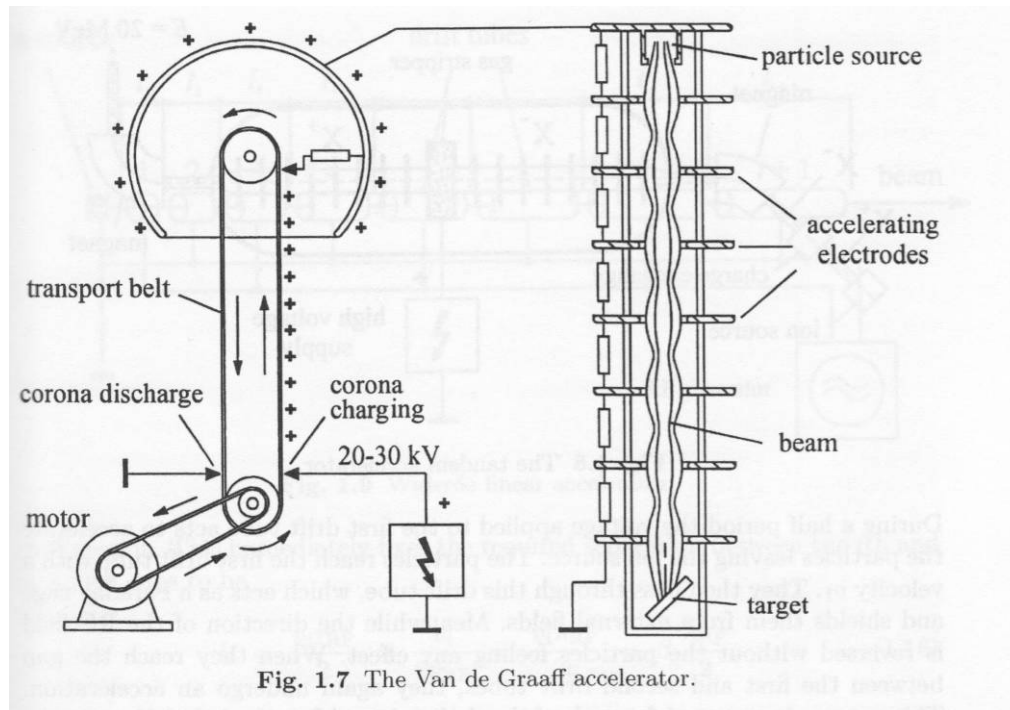

# Cyclotrons

Berkeley (1929)



Orsay (2000)



Proton Therapy PSI

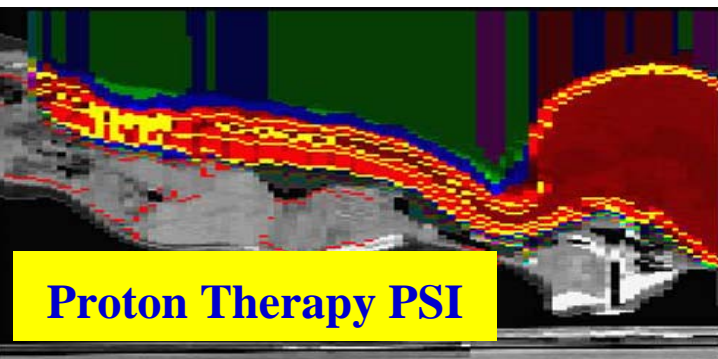

- Utilise motion in magnetic field:  
 $p \text{ (GeV/c)} = 0.3 q B R$
- Apply AC to two halves
- Lawrence achieved MeV particles with 28cm diameter
- Magnet size scales with momentum...

$$\omega = \frac{qB}{m}$$

- Still used for
  - Medical Therapy
  - Creating Radioisotopes
  - Nuclear Science

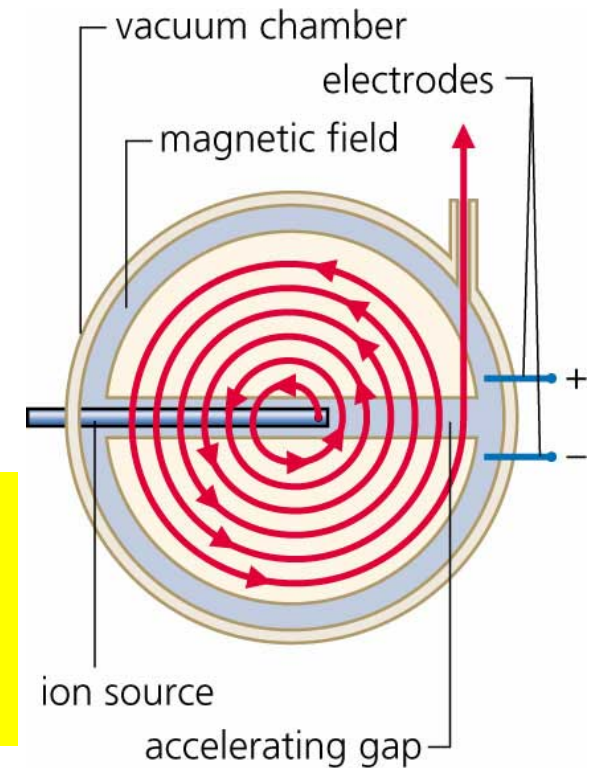

Precision Graphics



# Cyclotrons - Variations

## ■ Cyclotron limitations:

- Energy limit is quite low: 25 MeV per charge
- Non-relativistic velocity  $v < 0.15c$

## ■ Alternatives:

### □ Syncrocyclotron

- Keep magnetic field constant but decrease RF frequency as energy increases to compensate for relativistic effects.

### □ Isocyclotron

- Keep RF frequency the same but increase the radial magnetic field so that cyclotron frequency remains the same:
- Can reach ~600 MeV

$$\omega = \frac{qB(r(E))}{m(E)} = \text{const.}$$

### □ Synchrotron

- For very high energies. See later...

# Linear Accelerators

For energies greater than few MeV:

- Use multiple stages
- RF easier to generate and handle
- Bunches travel through resonant cavities
- Spacing and/or frequency changes with velocity
- Can achieve 10MV/m and higher
- 3km long Stanford Linac reached 45 GeV
- 30km ILC would reach 250 GeV.

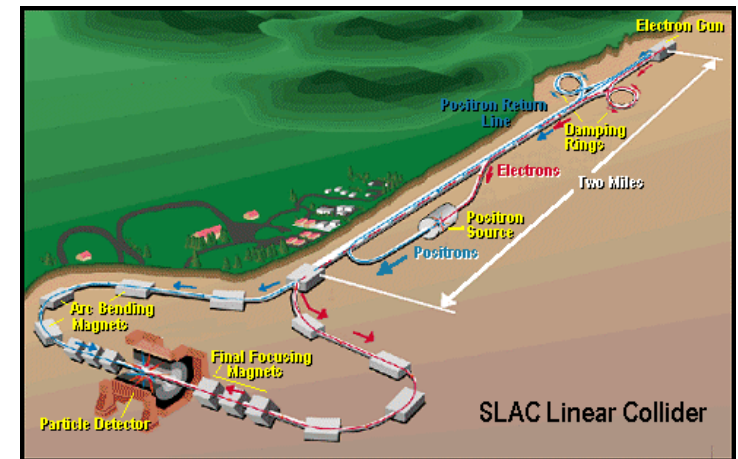
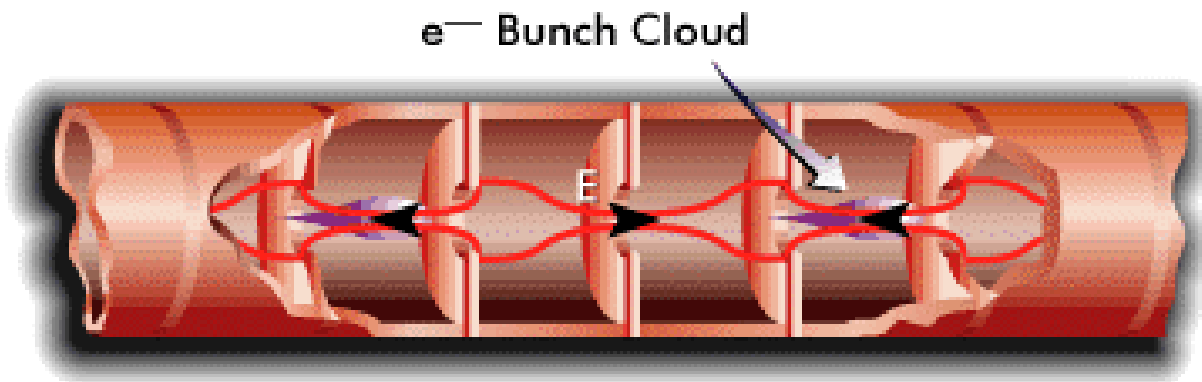
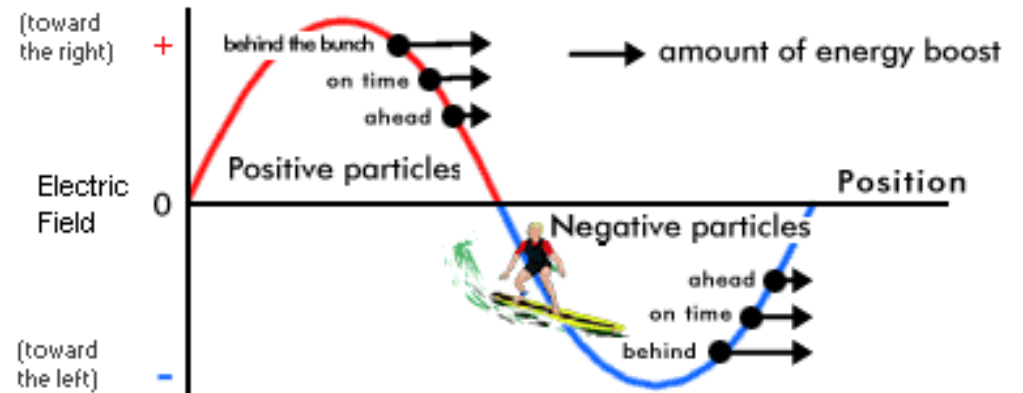

# Superconducting Cavities & Klystron

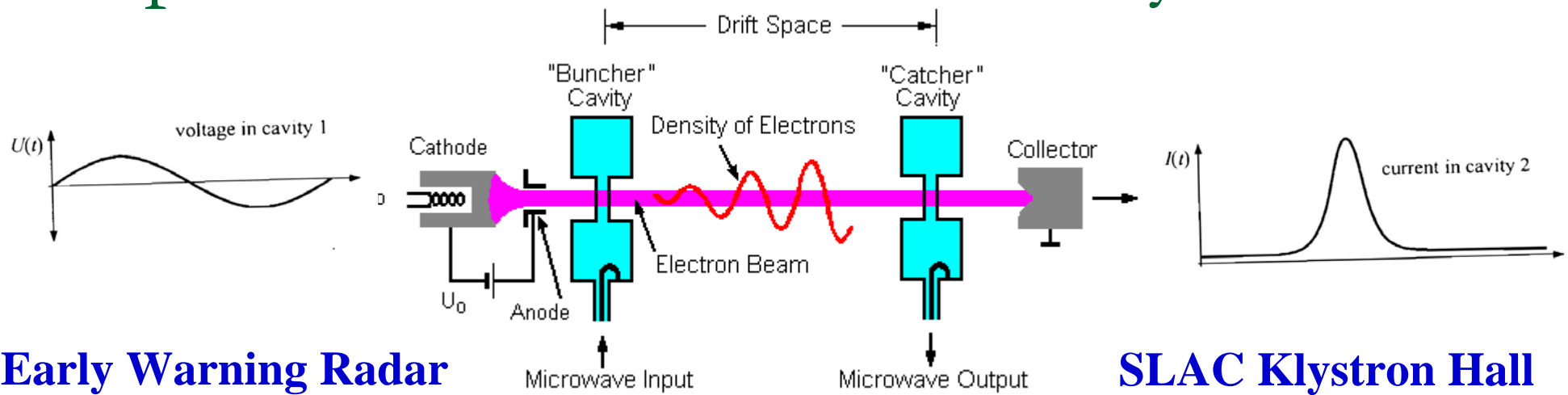

Early Warning Radar

SLAC Klystron Hall

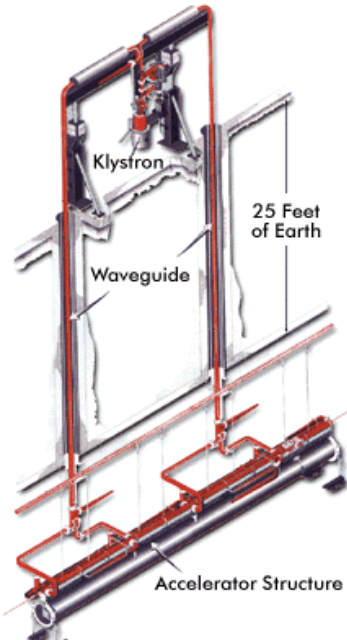
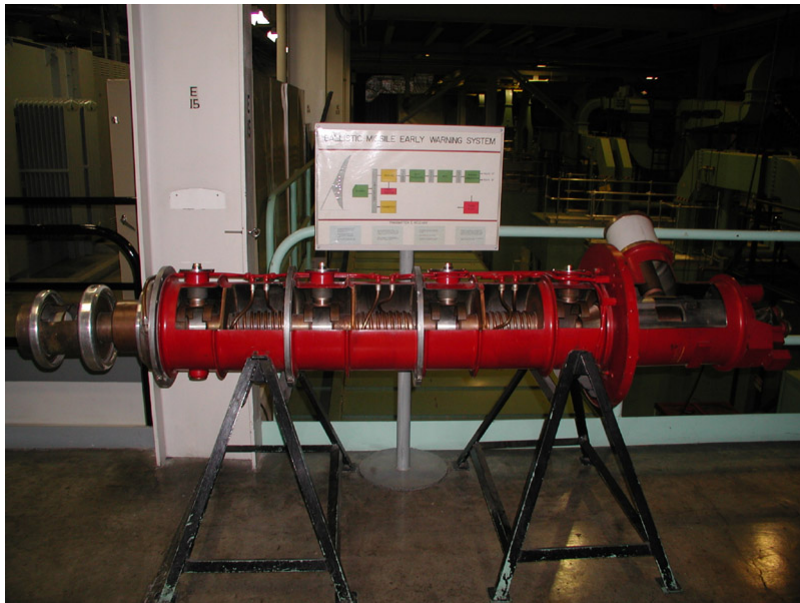

# Synchrotrons

- $p \text{ (GeV/c)} = 0.3 q B R$
- Cyclotron has constant  $B$ , increasing  $R$
- Increase  $B$  keeping  $R$  constant:
  - ❑ variable current electromagnets
  - ❑ particles can travel in small diameter vacuum pipe
  - ❑ single cavity can accelerate particles each turn
  - ❑ efficient use of space and equipment
- Discrete components in ring
  - ❑ cavities
  - ❑ dipoles (bending)
  - ❑ quadrupoles (focusing)
  - ❑ sextuples (achromaticity)
  - ❑ diagnostics
  - ❑ control

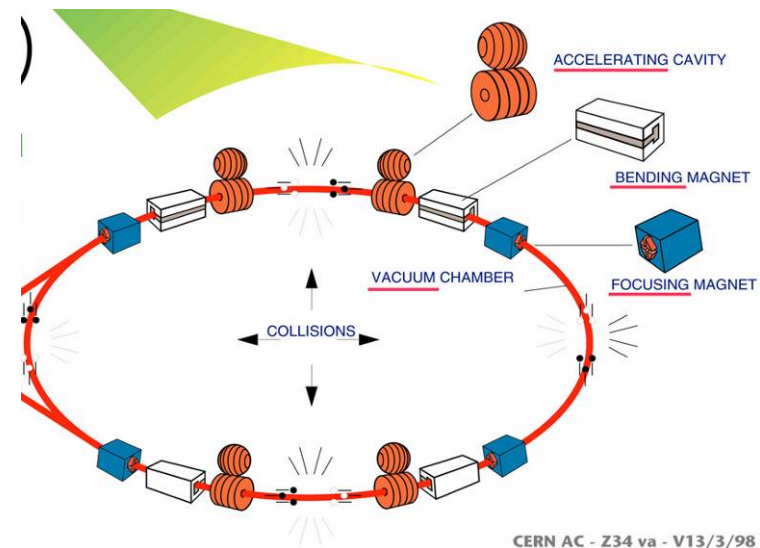

$$mv^2 = Bqv$$

$$\omega = \frac{v}{r} = \frac{Bq}{m}$$

$$f = \frac{Bq}{2m\pi} \frac{m_0}{m_0 + T}$$

# Synchrotron Radiation

- Accelerated charges radiate
- Average power loss per particle:
- Quantum process → spread in energy
- For a given energy  $\sim 1/\text{mass}^4$ 
  - (this comes from  $\gamma$  in the Power loss equation)
- Electron losses **much larger than** proton
  - High energy electron machines have very large or infinite  $R$  (i.e. linear).
- Pulsed, intense X-ray source may be useful for some things....



$$\text{Power loss (Watts)} = \frac{1}{6\pi\epsilon_0} \frac{e^2 a^2}{c^3} \gamma^4 \quad a = \frac{v^2}{R} \quad \gamma = \frac{E}{m_0}$$

$$\Rightarrow \text{Electron Power Loss per turn} = \frac{8.85 \times 10^{-5} E^4}{R} \text{ MeV/turn}$$

E in GeV, R in km.

$$\Rightarrow \text{Proton Power Loss per turn} = \frac{7.78 \times 10^{-3} E^4}{R} \text{ keV/turn}$$

E in TeV, R in km.

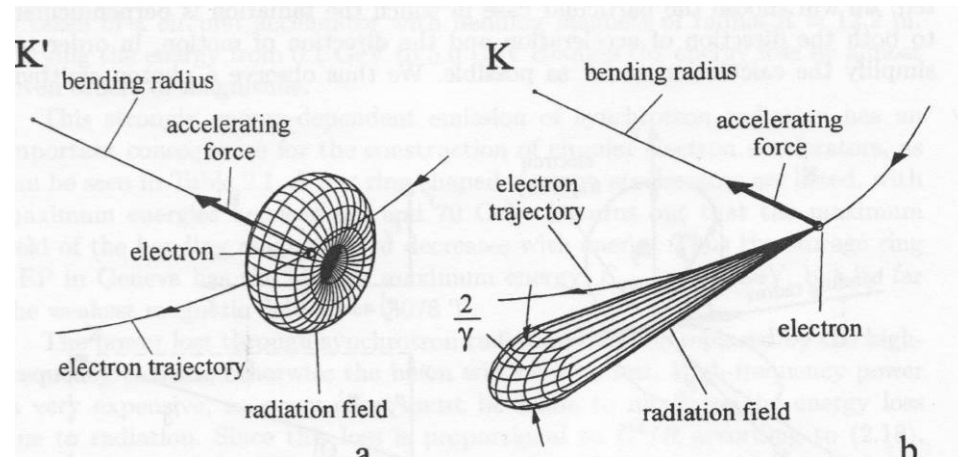

# Real Synchrotrons



**Bevatron, LBNL, USA**

**Grenoble, France**

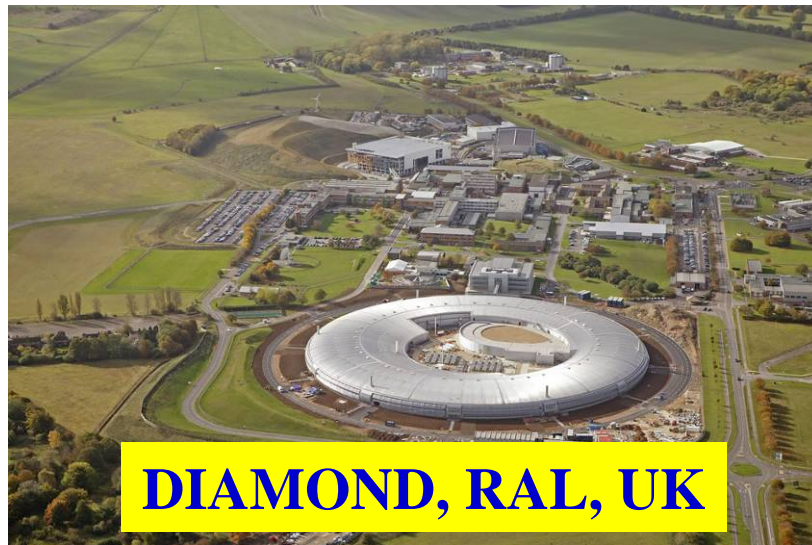

**DIAMOND, RAL, UK**

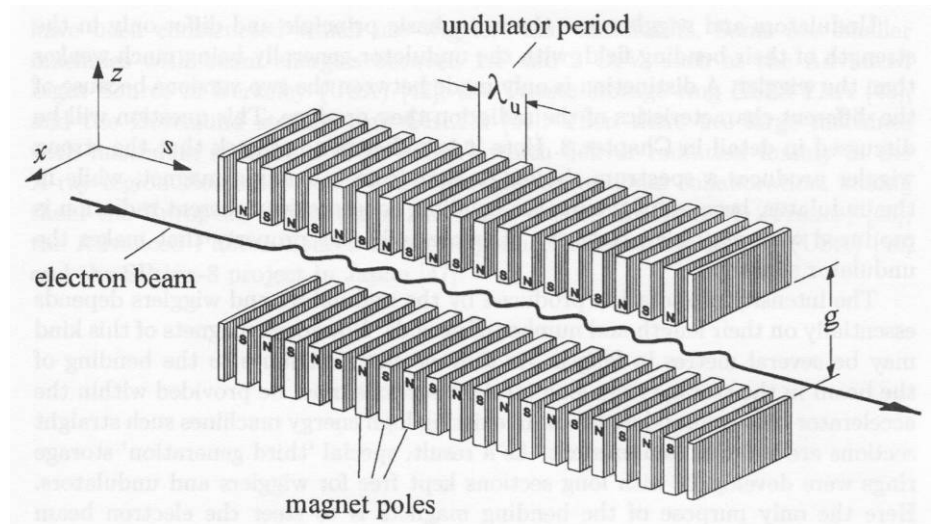

# Fixed Target Experiments

Beam incident on stationary target

- Interaction products have large momentum in forward direction
- Large “wasted” energy  $\Leftrightarrow$  small  $\sqrt{s}$
- Intense beams/large target  $\Rightarrow$  high rate
- Secondary beams can be made.

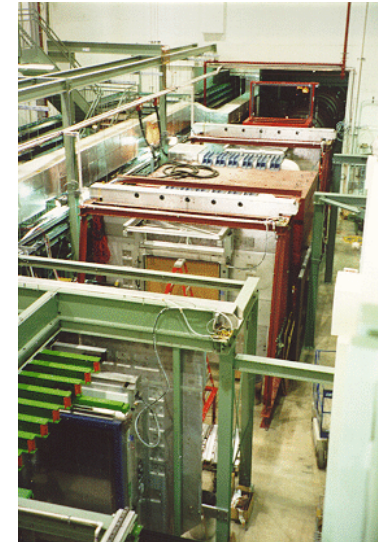

$$p_1 = (E_1, \bar{p}_1) \quad p_2 = (E_2, \bar{p}_2) \quad E^2 = p^2 + m_0^2$$

$$\text{Centre of Mass energy squared } s = E_{cm}^2 = (p_1 + p_2)^2$$

$$\Rightarrow E_{cm} = \left[ (E_1 + E_2)^2 - (\bar{p}_1 + \bar{p}_2)^2 \right]^{1/2}$$

# Fixed Target - Neutrino Beams

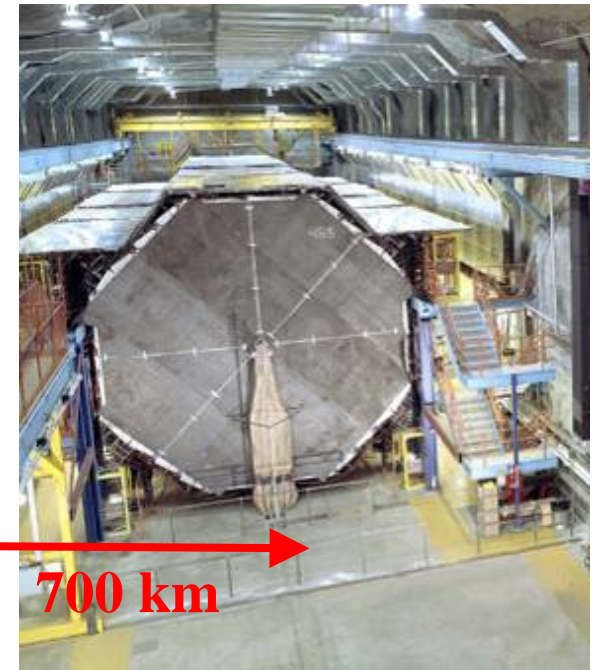
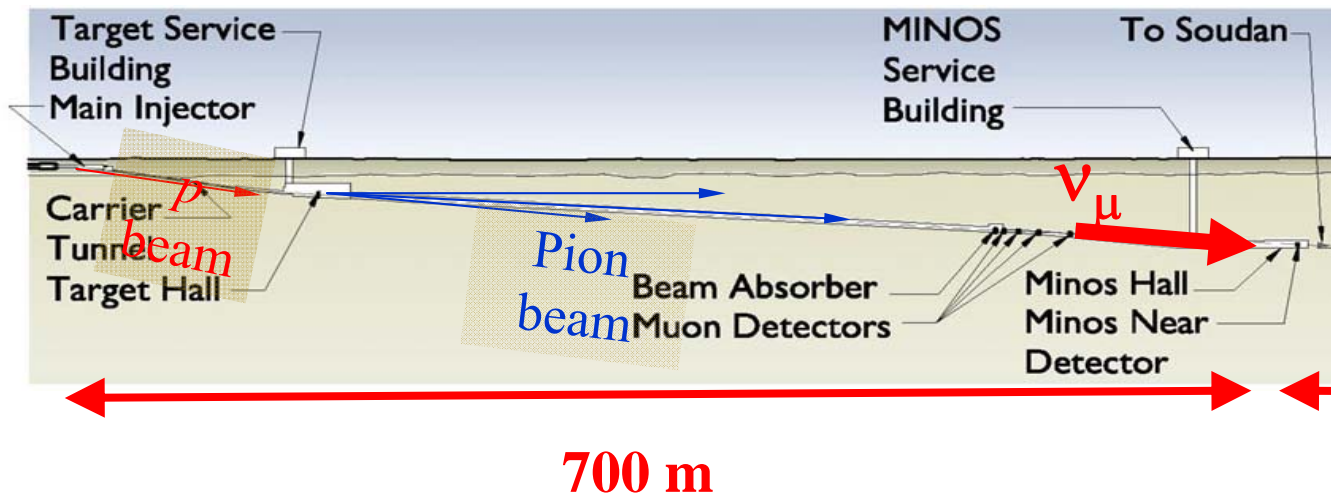

- Fermilab sends a  $\nu_{\mu}$  beam to Minnesota
- Looking for oscillations
- Detector at bottom of mine shaft



# Colliders

- Incoming momenta cancel
- $\sqrt{s} = 2E_{beam}$
- Same magnetic field deflects opposite charges in opposite directions  $\Rightarrow$   
*Antiparticle accelerator for free!*
  - particle/antiparticle quantum numbers also cancel
- *Technically challenging*

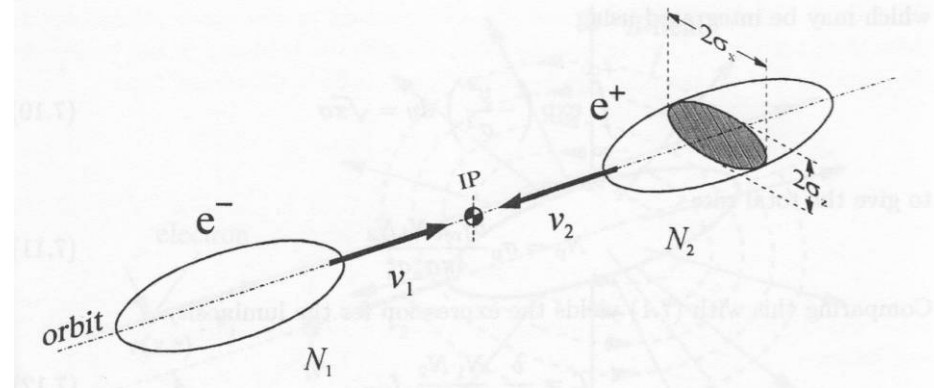

Event Rate  $R = L\sigma$

Current  $I_i = n_i e f N_b$

particles per bunch

Luminosity =  $f \frac{n_1 n_2}{4\pi\sigma_x\sigma_y} = \frac{I_1 I_2}{4\pi f N_b e^2 f \sigma_x \sigma_y}$

frequency

bunch size

#bunches

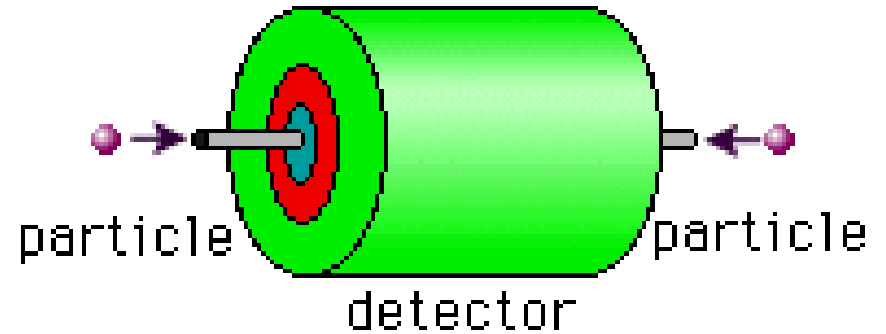

# Different Colliders

## ■ $p$ anti- $p$

- energy frontier
- difficult to interpret
- limited by anti- $p$  production
- *SPS, Tevatron*

## ■ $p p$

- high luminosity
- energy frontier
- *LHC*

## ■ $\mu^+ \mu^-$

- some plans exist

## ■ $e^+ e^-$

- relatively easy analysis
- high energies difficult
- *LEP, PEP, ILC...*

## ■ $e p$

- proton structure
- *HERA*

## ■ ion ion

- quark gluon plasma
- *RHIC, LHC*

## ■ $\nu \nu$

- Muon Collider !!!

# Complexes

- Synchrotrons can't accelerate particles from rest
- Designed for specific energy range, normally about factor of 10

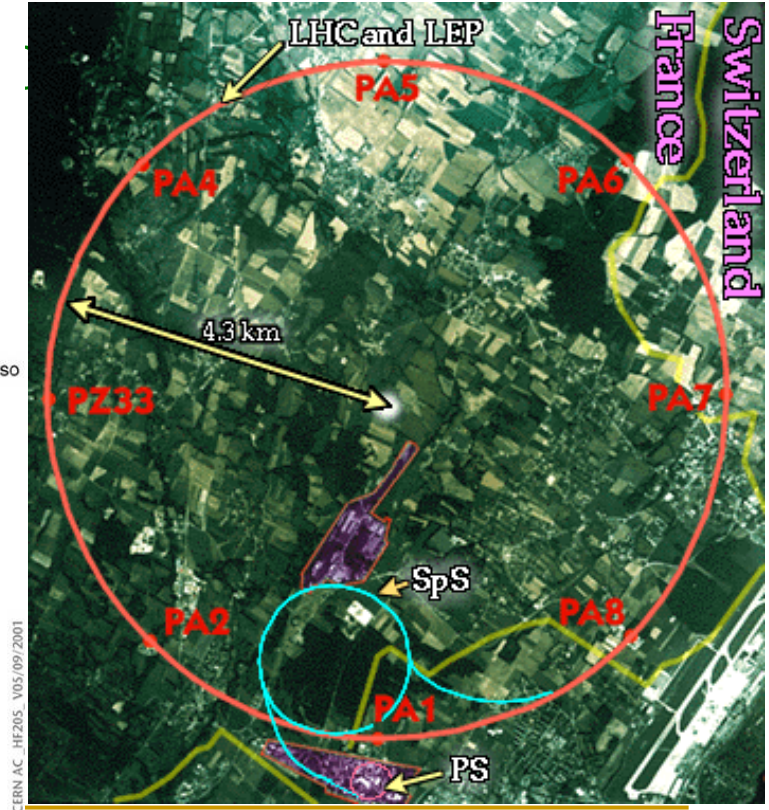
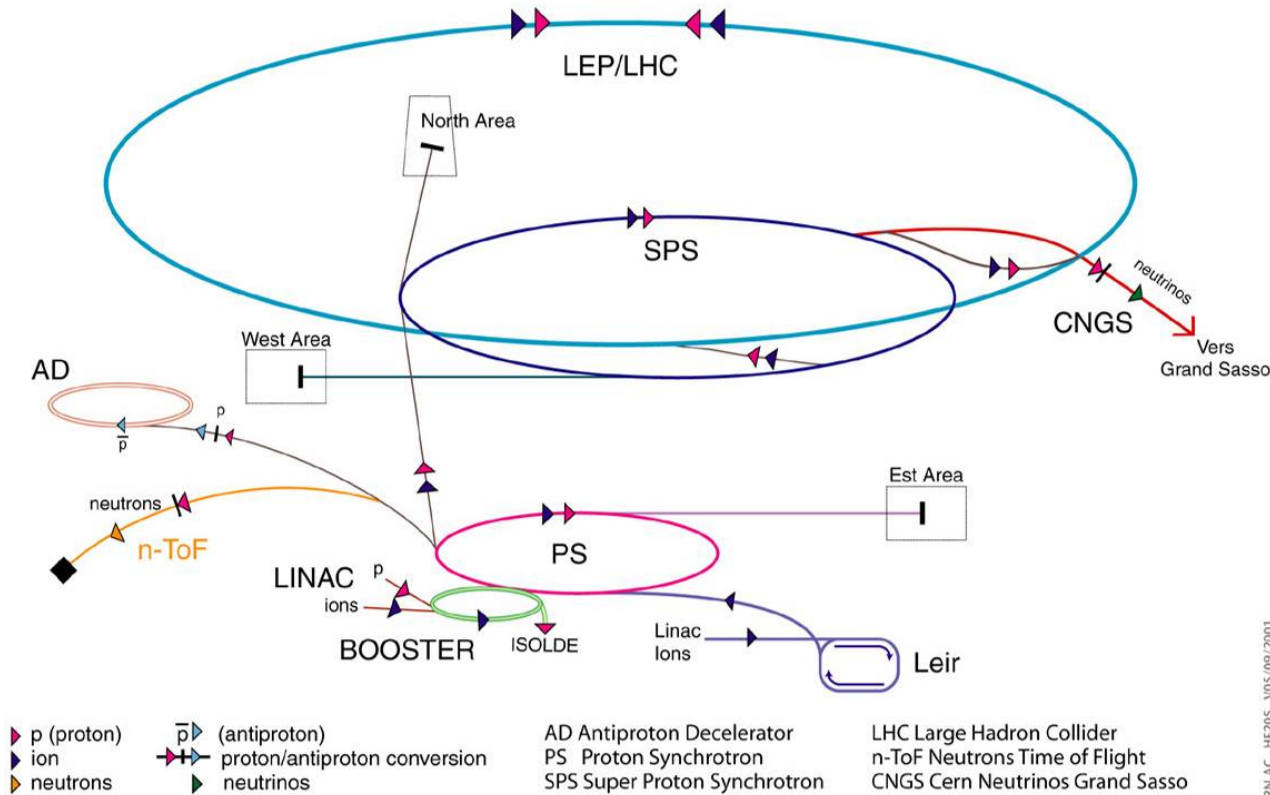

# Collider Parameters

	CESR (Cornell)	CESR-C (Cornell)	KEKB (KEK)	PEP-II (SLAC)	LEP (CERN)
Physics start date	1979	2002	1999	1999	1989
Physics end date	2002	—	—	—	2000
Maximum beam energy (GeV)	6	6	$e^- \times e^+ : 8 \times 3.5$	$e^- : 7-12$ (9.0 nominal) $e^+ : 2.5-4$ (3.1 " ) (nominal $E_{\text{cm}} = 10.5$ GeV)	101 in 1999 (105=max. foreseen)
Luminosity ( $10^{30} \text{ cm}^{-2}\text{s}^{-1}$ )	1280 at 5.3 GeV/beam	35 at 1.9 GeV/beam	11305	6777	24 at $Z^0$ 100 at $> 90$ GeV
Time between collisions ( $\mu\text{s}$ )	0.014 to 0.22	0.014 to 0.22	0.008	0.0042	22

**Full details at [pdg.lbl.gov](http://pdg.lbl.gov)**

	HERA (DESY)	TEVATRON (Fermilab)	RHIC (Brookhaven)			LHC (CERN)	
Physics start date	1992	1987	2000			2007	2008
Physics end date	—	—	—			—	
Particles collided	$ep$	$p\bar{p}$	$pp$ (pol.)	Au Au	d Au	$pp$	Pb Pb
Maximum beam energy (TeV)	$e$ : 0.030 $p$ : 0.92	0.980	0.1 40% pol	0.1 TeV/u	0.1 TeV/u	7.0	2.76 TeV/u
Luminosity ( $10^{30} \text{ cm}^{-2}\text{s}^{-1}$ )	75	50	6	0.0004	0.07	$1.0 \times 10^4$	0.001
Time between collisions ( $\mu\text{s}$ )	0.096	0.396	0.213			0.025	0.100

## Some notable accelerators

Type	Name	Size	Start Year	Place	Energy
Cockcroft-Walton		3m	1932	Cambridge	0.7MeV
Cyclotron	9"	9"	1931	Brookhaven	1.0 MeV
Cyclotron	184"	184"	1942	Brookhaven	100 MeV
Synchrotron	Cosmotron	72m	1953	Brookhaven	3.3 GeV
Synchrotron	AGS	72m	1960	Brookhaven	33 GeV
Collider	LEP	27km	1995	CERN	104 GeV
Collider	LHC	27km	2007?	CERN	7 TeV

---

# Summary of Lecture I

- Admin
- Particle Sources
  - Natural Radiation
  - Cosmic Rays
  - Reactors
  - Accelerators
- Accelerators
  - Cockcroft Walton
  - Van der Graaf
  - Cyclotron
  - Synchrotron
  - Linear Accelerator
- Antiparticle Production
- Collider Parameters

---

Next Time...

*Charged particle interactions and detectors*